

IP&E News

1st Quarter 2026

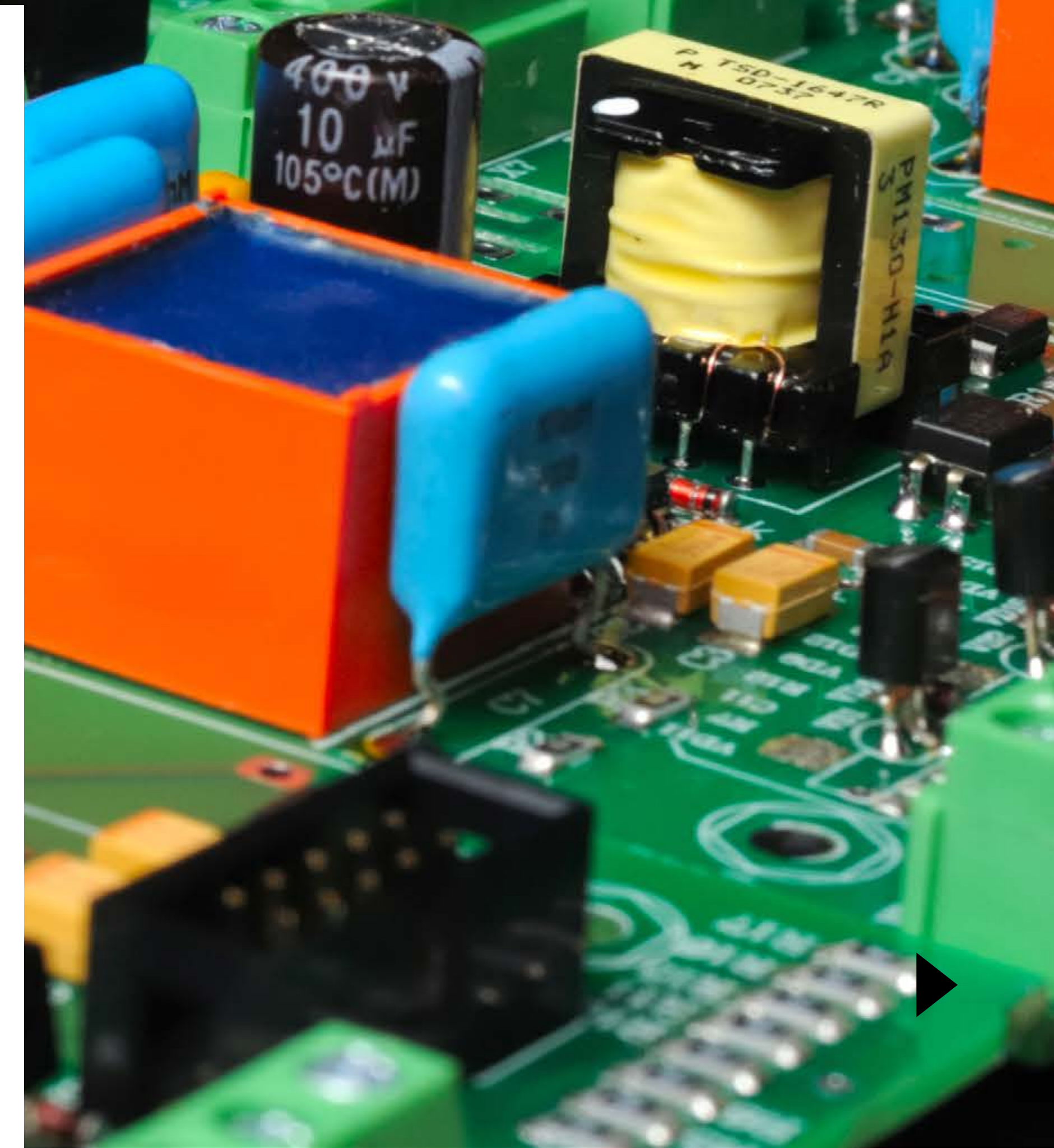



Content

Manufacturers

Linecard

Home

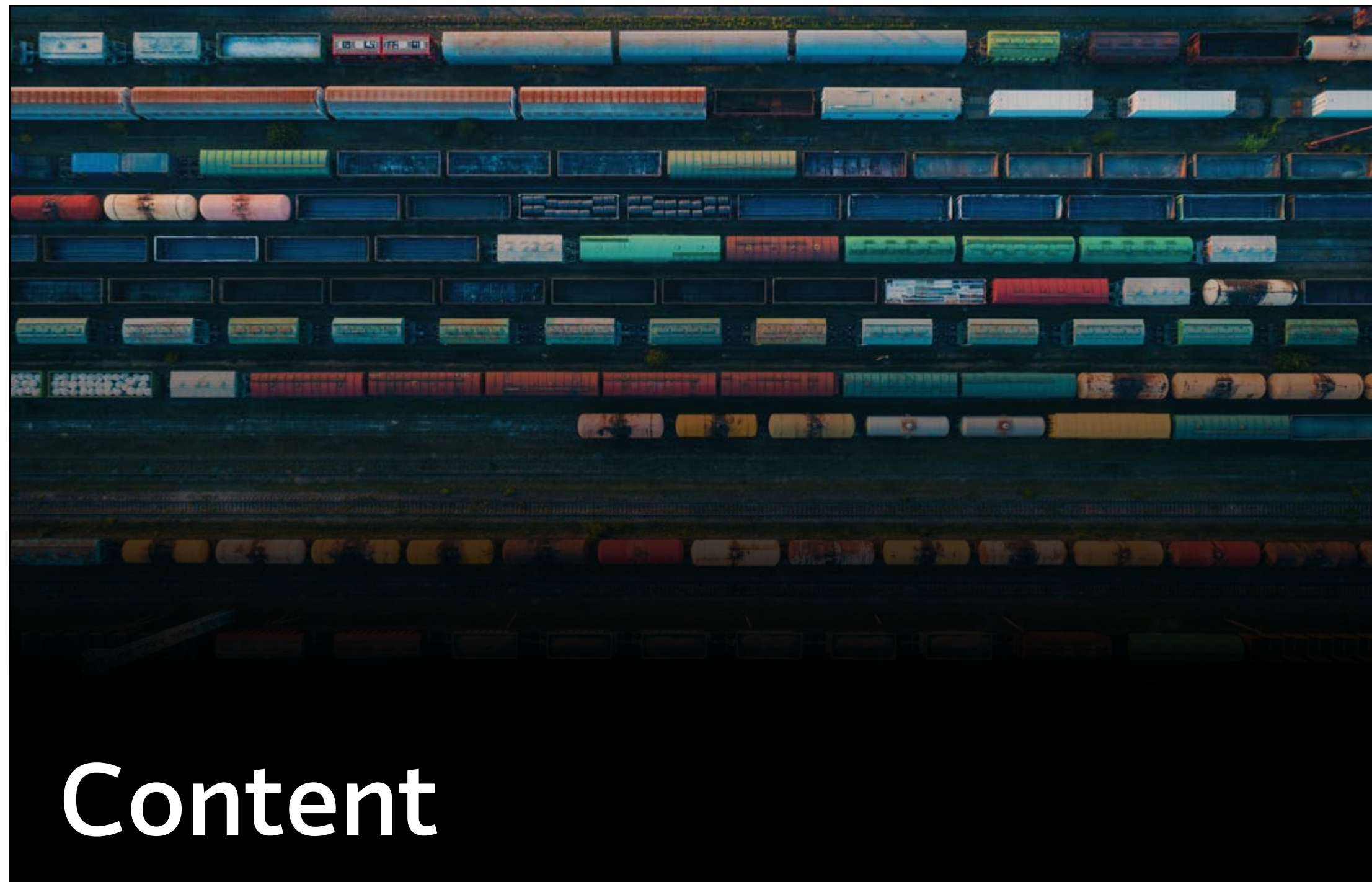

Content

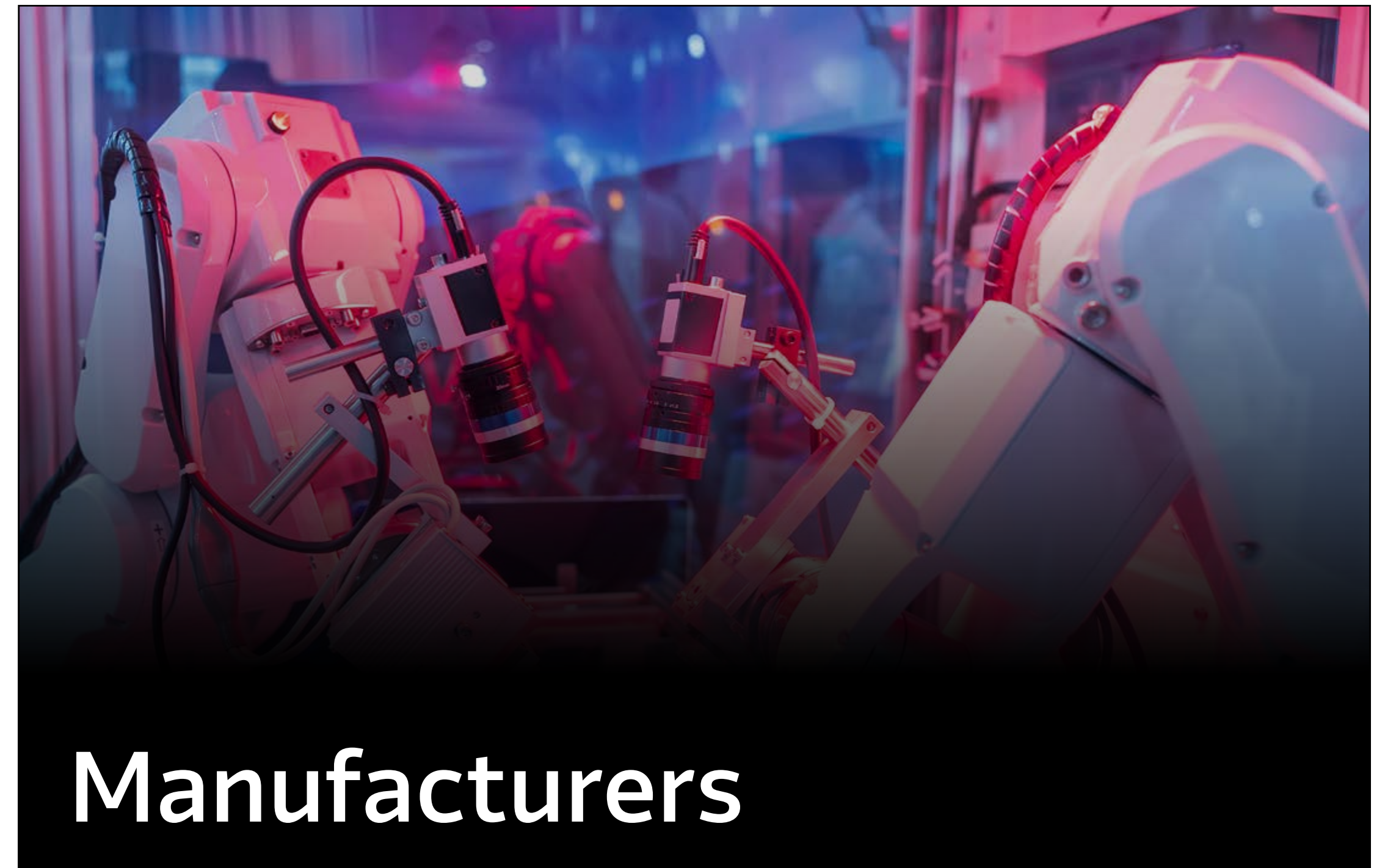

Manufacturers



Linecard



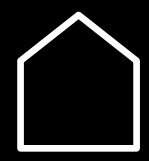

Content

Arrow ▶ [When the Semiconductor is faster than Physics allows
IP&E Linecard](#)

Amphenol ▶ [EnergyKlip™ sets a new standard for high-current power interconnects](#)

Bourns ▶ [Engineering the Future of High-Power Performance](#)

Bulgin ▶ [Built for harsh Environments. Designed with the Future in Mind](#)

KOA ▶ [High Power Chip & Ceramic Resistors](#)

Littelfuse ▶ [LS0502SCD33 eFuse](#)

Lumberg ▶ [Series 45 – Electrical performance and mechanical robustness
Compact power interconnects for high voltage and high current applications](#)

NIC Components ▶ [High-Power Reliability for Demanding Designs](#)

Ohmite ▶ [High Power Resistive and Thermal Solutions from Ohmite](#)

Panduit ▶ [VeriSafe Absence of Voltage Tester](#)

Samtec ▶ [Simplifying AC Power Delivery with Pre-Assembled Cables](#)

Susumu ▶ [High Power Resistor Portfolio](#)

TDK ▶ [TDK's DC-Link Capacitors: ModCap family](#)

TE Connectivity ▶ [Power Resistors engineered for demanding Performance](#)

Yageo/Kemet ▶ [GTX Series EMI-RFI Filters
Power Up Your Design with Power Box DC Link Film Capacitors](#)

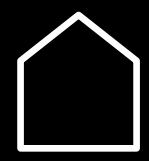

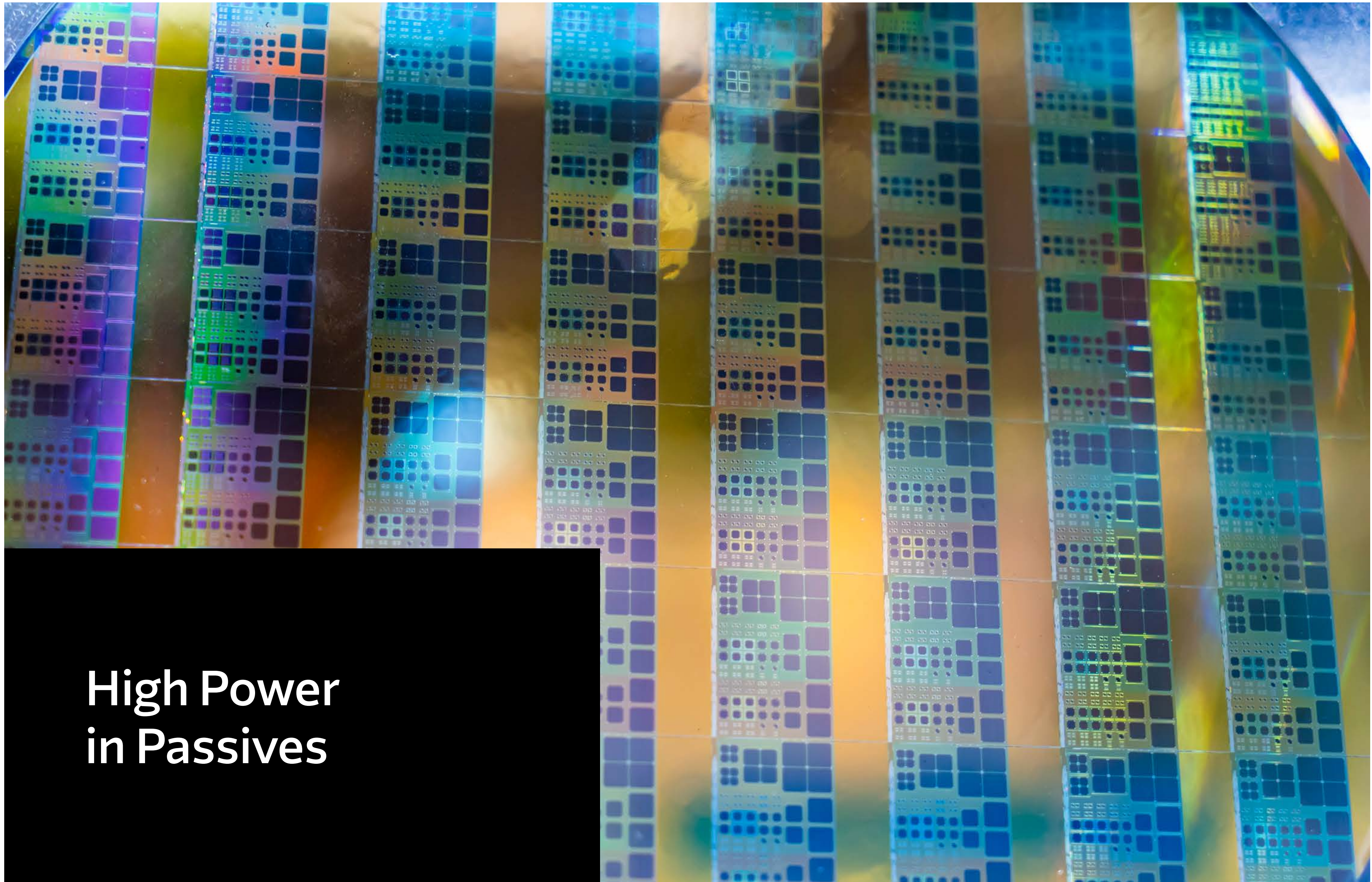
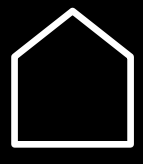

High Power in Passives



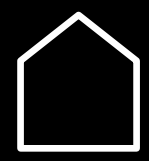

When the Semiconductor is faster than Physics allows

Selection and Dimensioning of Passive Components in SiC and GaN Power Electronics

SiC and GaN semiconductors have pushed power electronics into a new speed class. Voltage slew rates of several tens up to well above one hundred kV/μs, combined with extremely high current slew rates, shift the critical part of the design: the switch is no longer the limiting element – passive components and their parasitic properties are.

Effects that were considered negligible side effects in silicon IGBT systems become dominant circuit parameters in wide-bandgap (WBG) applications. Inductors, transformers, and capacitors no longer behave like ideal L or C elements but like complex high-frequency networks. This is exactly where many typical problems of modern SiC and GaN systems originate: current spikes, overvoltage, EMI issues, and unexpected component stress.

Parasitic Elements Become Active Circuit Elements

The reason lies in the extreme temporal changes of electrical and magnetic quantities.

Parameter	Si-IGBT	SiC MOSFET	GaN HEMT
dv/dt	5–10 kV/μs	30–80 kV/μs	50–150 kV/μs
di/dt	moderate	high	extremely high
switching frequency	< 50 kHz	50–200 kHz	100 kHz – MHz

Transformers and Inductors – From Energy Storage to HF Systems

Magnetic components are particularly critical in WBG applications because they combine several parasitic effects simultaneously.

Winding capacitances as current injectors

Especially relevant are:

- Primary ↔ secondary capacitance
- Primary ↔ core capacitance
- Inter-layer winding capacitances

The capacitance between primary winding and core is often underestimated. With steep voltage transitions, it generates displacement currents directly into the core and thus into the reference potential. These current spikes can reach several amperes – even with capacitance values only in the double-digit pF range. The result is common-mode currents, increased EMI emissions, and additional stress on switches and snubbers.

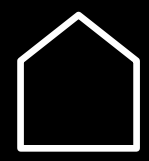

When the Semiconductor is faster than Physics allows

Selection and Dimensioning of Passive Components in SiC and GaN Power Electronics

Design trade-off:

leakage inductance vs. capacitance

Traditionally, transformers are optimized for minimal leakage inductance. This requires tight magnetic coupling – and inevitably increases winding capacitance. In SiC and GaN designs, this optimum shifts. **Minimal leakage inductance is not automatically ideal** if it leads to large capacitive current spikes.

The transformer thus becomes a high-frequency optimization problem. Winding structure, chamber segmentation, shielding windings, wire geometry, or segmented foil windings are no longer details but central design parameters.

Capacitors – When ESL Becomes an Overvoltage Source

In WBG systems, the benefit of a capacitor is no longer determined primarily by its capacitance, but by its

parasitic inductance (ESL). At high di/dt , even a few nanohenries of ESL can generate significant voltage spikes. These add to the actual switching voltage and may exceed the maximum ratings of SiC or GaN devices.

In practice, it often turns out: the capacitor's nominal voltage rating is sufficient – **the layout and connection geometry are not**. Reverse-geometry MLCCs, multiple small capacitors in parallel, and extremely short current loops are more decisive than the pure capacitance value.

Parasitics as Active Sources

At high dv/dt , parasitic capacitance is no longer a marginal effect but a direct current source:

$$I = C \cdot \frac{dV}{dt}$$

Example

$$C_{pk} = 100 \text{ pF}$$

$$dv/dt = 50 \text{ kV}/\mu\text{s}$$

→ **I = 5 A displacement current** directly into the core or reference potential.

Likewise, any parasitic inductance becomes a voltage source:

$$V = L \cdot \frac{di}{dt}$$

$$ESL = 2 \text{ nH}$$

$$di/dt = 100 \text{ A}/\mu\text{s}$$

→ **200 V overvoltage** generated by the capacitor itself.

Thus, winding capacitances, leakage inductances, and capacitor ESL are no longer disturbance factors – they actively determine switching behavior.

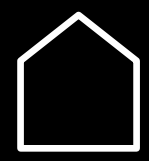

When the Semiconductor is faster than Physics allows

Selection and Dimensioning of Passive Components in SiC and GaN Power Electronics

Example circuit for a VIPERGAN100

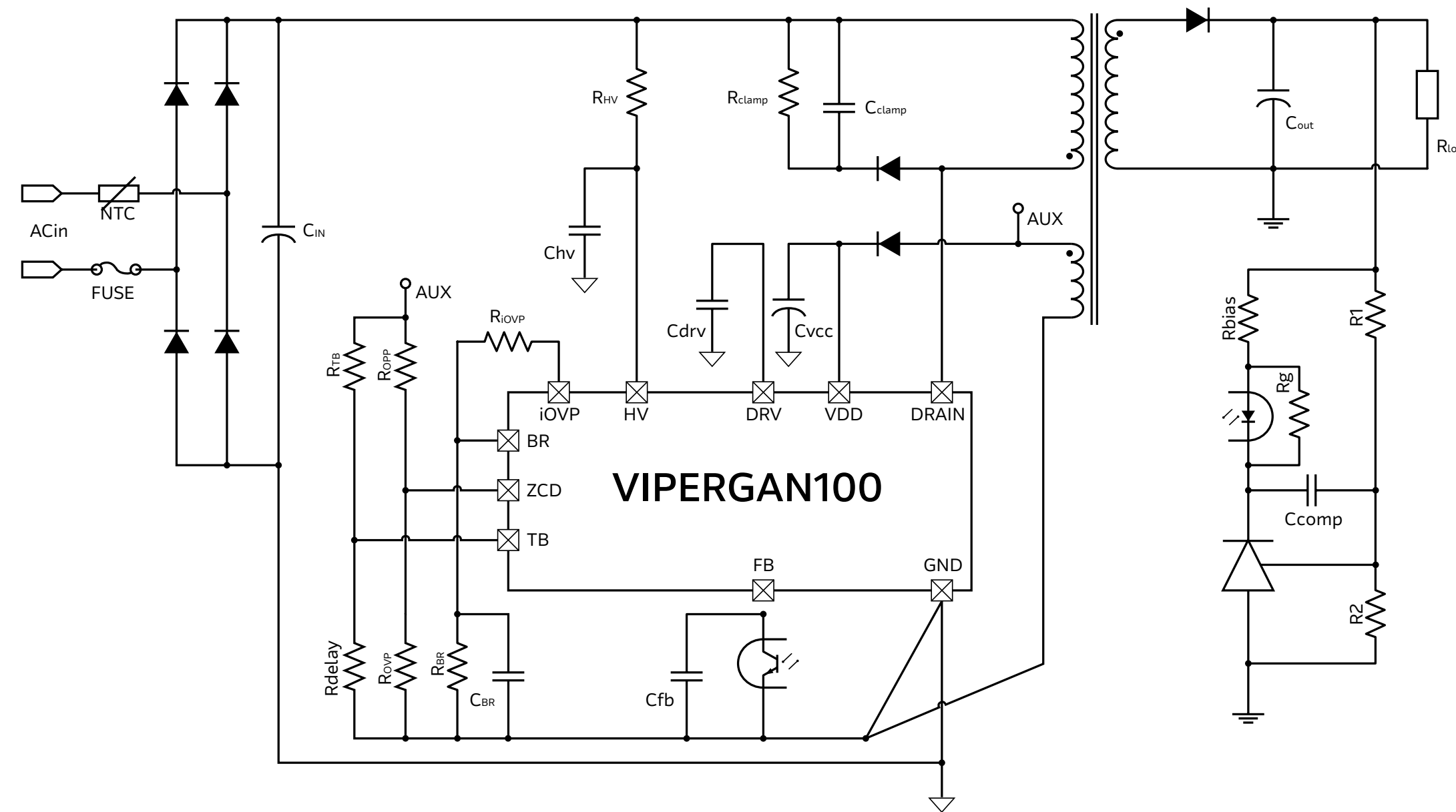

Figure 1: STMicroelectronics, VIPERGAN100W Datasheet, DS14886 Rev. 2, Jul. 2025. Available: <https://www.st.com/resource/en/datasheet/vipergan100w.pdf>

265 V_{AC} full load V_{DRAIN} & I_{DRAIN}

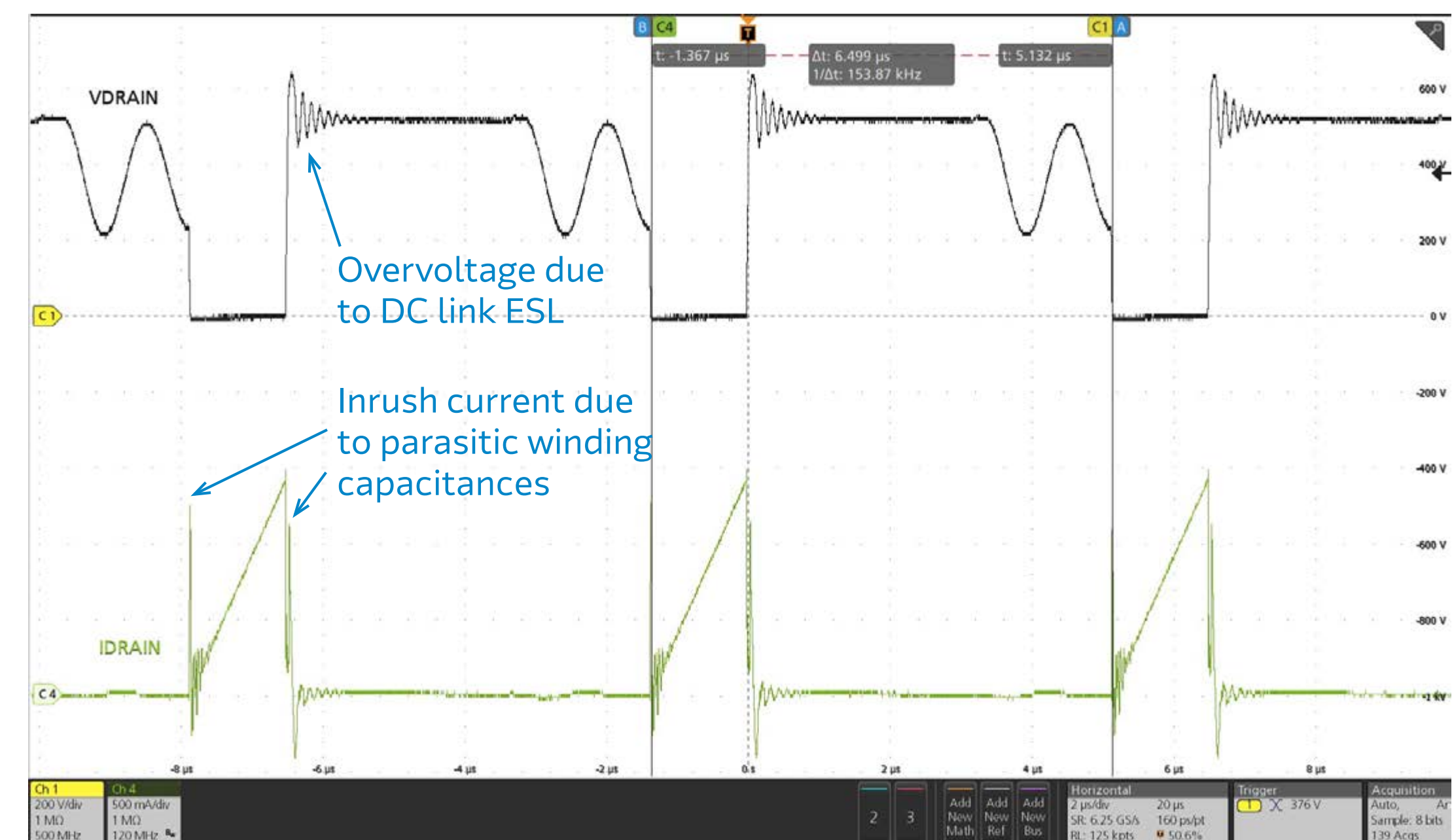
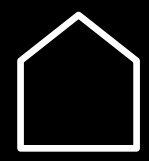

Figure 2: STMicroelectronics, EVLVIPGAN50FL: 15 V / 50 W isolated flyback with VIPERGAN50, Application note AN5844, Rev. 2, June 2024, STMicroelectronics. Available: [st.com/resource/en/application_note/an5844-evlvipgan50fl-15-v50-w-isolated-flyback-with-vipergan50-stmicroelectronics.pdf](https://www.st.com/resource/en/application_note/an5844-evlvipgan50fl-15-v50-w-isolated-flyback-with-vipergan50-stmicroelectronics.pdf)



When the Semiconductor is faster than Physics allows

Selection and Dimensioning of Passive Components in SiC and GaN Power Electronics

Unintended Resonances

The semiconductor's C_{oss} , winding capacitances, leakage inductances, and capacitor ESL easily form high-frequency resonant circuits in the tens-of-MHz range. These cause overshoot, ringing, and additional semiconductor stress. Such effects often become visible only when prototypes are tested under real conditions.

Core Losses with Fast Flux Changes

Not only ΔB but also $\Delta B/\Delta t$ matters. Rapid flux changes increase eddy current and remagnetization losses, even at moderate flux density. Ferrite materials that are efficient at low frequencies can exhibit significantly higher losses with steep edges. Core material selection must therefore consider both switching frequency and edge steepness.

Insulation and Partial Discharge

High dv/dt significantly stresses insulation systems. Inter-layer insulation, coatings, and potting materials may be locally overstressed. Partial discharge often occurs much earlier in WBG systems than in comparable silicon designs. Insulation design therefore becomes a high-frequency topic.

Why standard Passive Components are often insufficient

Datasheets typically specify inductance or capacitance at low frequencies. Information about behavior under extreme edges or in the tens-of-MHz range is often missing – yet this is where real stress occurs in SiC and GaN applications.

Engineering Support as a Key Factor

Successful WBG designs are based on the understanding that parasitic

elements are an integral part of the circuit. In practice, standard components often need to be modified or fully customized — especially magnetics and HF-optimized capacitor networks.

Close collaboration between designers, component manufacturers, and technically skilled distributors is therefore becoming increasingly important. Simulation of winding capacitances, optimization of layout and current paths, and selection of suitable materials are no longer secondary topics but decisive for efficiency, EMI performance, and reliability.



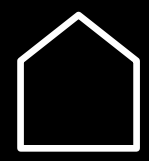

When the Semiconductor is faster than Physics allows

Selection and Dimensioning of Passive Components in SiC and GaN Power Electronics

Conclusion

With SiC and GaN, the focus of power electronics shifts from semiconductor physics toward the high-frequency physics of passive components.

Winding capacitances, ESL, and leakage inductances are no longer parasitic side effects but actively define system behavior. Ignoring these effects early in the design risks instability, overvoltage, and efficiency loss.

Careful selection and dimensioning of passive components is therefore a key success factor in modern WBG power electronics.

Typical Project Support Areas

Magnetics

- Simulation of winding capacitances
- Optimization of layer structure
- Custom transformer design

Capacitor networks

- Selection of ESL-optimized types
- Parallel capacitor concepts
- HF layout consulting

System analysis

- Identification of resonances
- Current path optimization
- EMI risk assessment

Samples and special solutions

If a catalog part does not fit, we work with manufacturers on:

- Custom magnetics
- Low-ESL capacitor solutions
- Adapted insulation systems

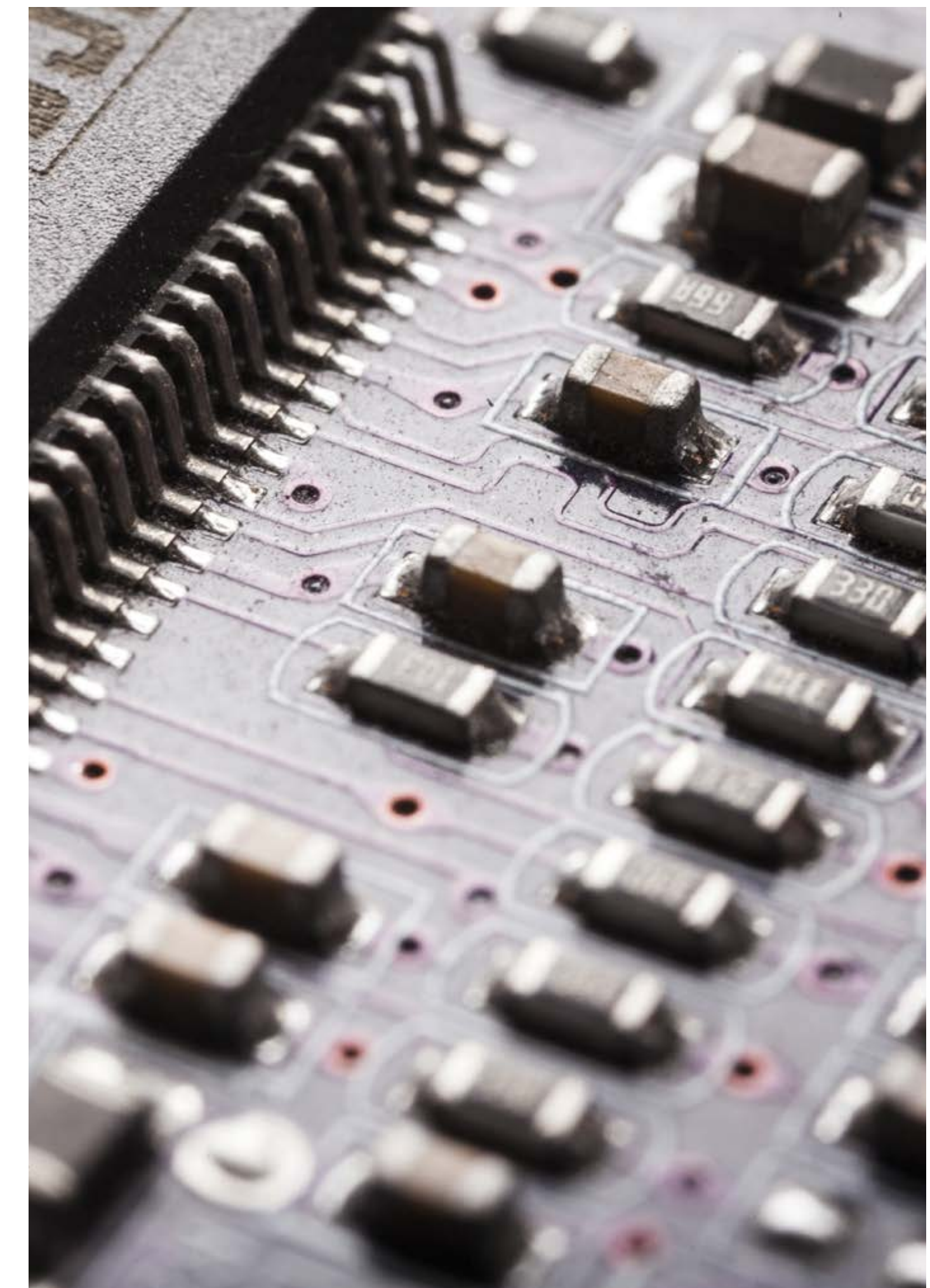

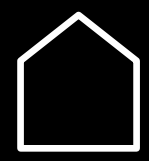

EnergyKlip™ sets a new standard for high-current power interconnects

Industrial Battery Module Connector for Energy Markets

EnergyKlip™ series from Amphenol is engineered with high current contact technology to address the increasing power demands of energy and automotive applications. These high-power connectors are USCAR-2 certified, UL94V-0 rated, and feature IP67 sealing for reliable performance in harsh environments. The portfolio includes EK160 and EK350 connector systems, purpose built to deliver robust and dependable interconnections for industrial and commercial battery storage solutions.

Features of EnergyKlip™ Connectors
High Current Capabilities: The EnergyKlip™ connector series boasts connectors with impressive current ratings, including the EK160, rated for 160 A per contact, and the EK350, which can handle up to 350 A per contact. This power range flexibility makes

them suitable for applications such as automotive and industrial.

Durable Construction: Both the EK160 and EK350 connectors are engineered with resilience in mind. Hence, they come with USCAR-2 certification, UL94V-0 rating, and IP67 rating, making them suitable for harsh environments.

Design Flexibility: EnergyKlip™ provides versatile connection options, supporting both cable and flexible busbar configurations, offering flexibility in system designs.

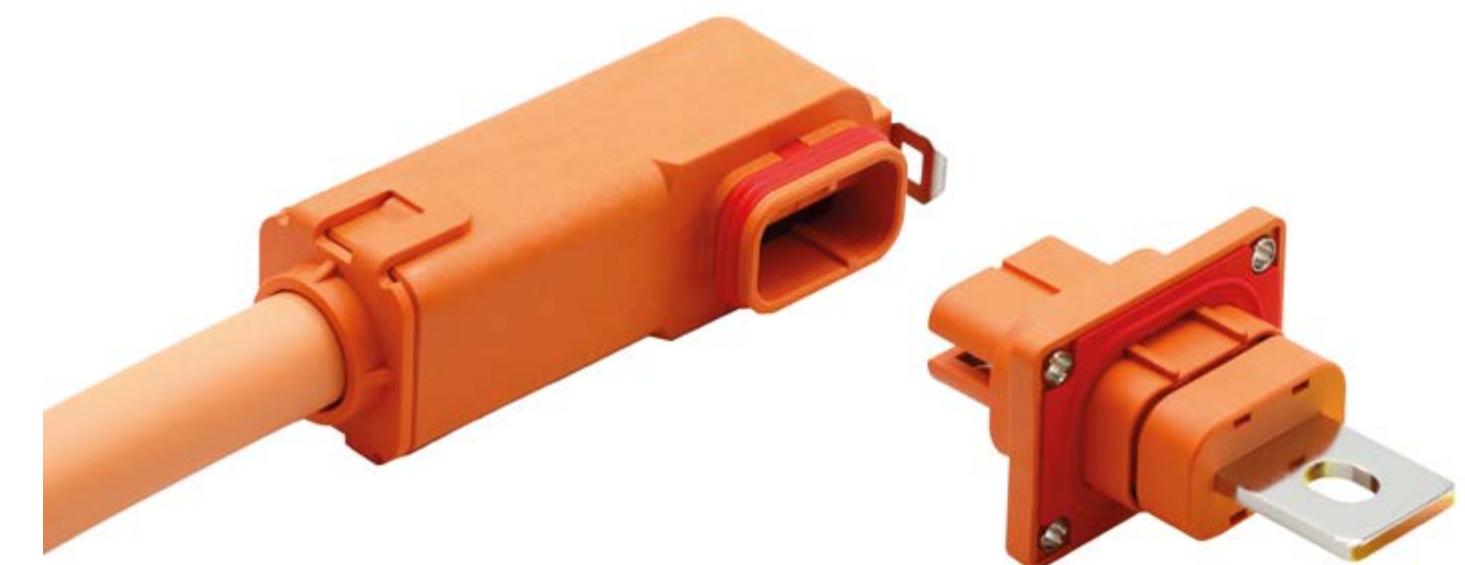

EnergyKlip™ EK350

- Rated up to 350 A per contact
- IP67 rated seal
- Robust latching system

[Applications](#)

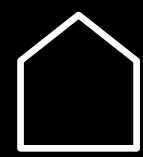

EnergyKlip™ sets a new standard for high-current power interconnects

Industrial Battery Module Connector for Energy Markets

EnergyKlip™ series from Amphenol is engineered with high current contact technology to address the increasing power demands of energy and automotive applications. These high-power connectors are USCAR-2 certified, UL94V-0 rated, and feature IP67 sealing for reliable performance in harsh environments. The portfolio includes EK160 and EK350 connector systems, purpose built to deliver robust and dependable interconnections for industrial and commercial battery storage solutions.

Features of EnergyKlip™ Connectors
High Current Capabilities: The EnergyKlip™ connector series boasts connectors with impressive current ratings, including the EK160, rated for 160 A per contact, and the EK350, which can handle up to 350 A per contact. This power range flexibility makes

them suitable for applications such as automotive and industrial.

Durable Construction: Both the EK160 and EK350 connectors are engineered with resilience in mind. Hence, they come with USCAR-2 certification, UL94V-0 rating, and IP67 rating, making them suitable for harsh environments.

Design Flexibility: EnergyKlip™ provides versatile connection options, supporting both cable and flexible busbar configurations, offering flexibility in system designs.

EnergyKlip™ EK350

- Rated up to 350 A per contact
- IP67 rated seal
- Robust latching system



Applications

- **EnergyKlip™** connectors are designed with rugged applications in mind
- **Industrial Battery Modules:** High-current capability and rugged design ensure reliable performance in demanding battery systems.
- **Energy storage solutions (ESS):** Supports high-power ESS installations for grid stabilization and scalable energy systems.
- **E-mobility:** ideal for e-mobility applications, providing reliable connections for electric vehicles.
- **Industrial Chargers:** Built to withstand harsh environments in industrial charging systems.
- **Battery backup units:** Delivers reliable power connections for backup systems during outages.

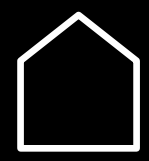
**BOURNS®**

Engineering the Future of High-Power Performance with Bourns

From advanced magnetics and planar technologies to IsoMOV® hybrid protection and precision current sensing, Bourns delivers the efficiency, reliability, and innovation powering AI servers, EV/HEVs, renewable energy, and next-generation industrial systems.

Bourns offers the cutting-edge technologies that enable greater efficiency, precision, and reliability in next-generation power systems. Meeting application needs are innovatively designed high-performance magnetics components – including power and signal transformers, inductors, current sense solutions, power resistors, current sense solutions, circuit protection devices, and position sensors.

These components are specifically engineered to support advanced application capabilities in AI servers, EV/HEV systems, industrial automation, renewable energy and high-speed data communications. By integrating advanced magnetic materials with compact, thermally-efficient structures, Bourns' solutions help designers achieve performance targets and accelerate time-to-market.

Of particular importance for high power designs, are Bourns' high current/impedance common mode chokes for superior EMI suppression, reinforced high creepage/clearance transformers (including automotive grade), customizable flyback and gate drive transformers, and the latest advancements in planar technology and custom magnetics.

For example, IsoMOV® Hybrid Protectors make excellent solutions for power protection. They deliver the benefits of both Metal Oxide Varistors (MOVs) and Gas Discharge Tubes (GDTs) combining the fast response of MOVs with the robustness of GDTs. This powerful combination offers superior protection against transient overvoltage threats that help maximize system efficiency and uptime.

Bourns also has a full line of precision current sensing products and shunt resistors, which deliver superior linearity, accuracy, and thermal stability, enabling safer and more reliable energy conversion in today's high power density applications.

Look to Bourns to help accelerate innovation and ensure robust performance from component to system level. The company's expanding product portfolio continues to evolve in step with emerging technology demands.

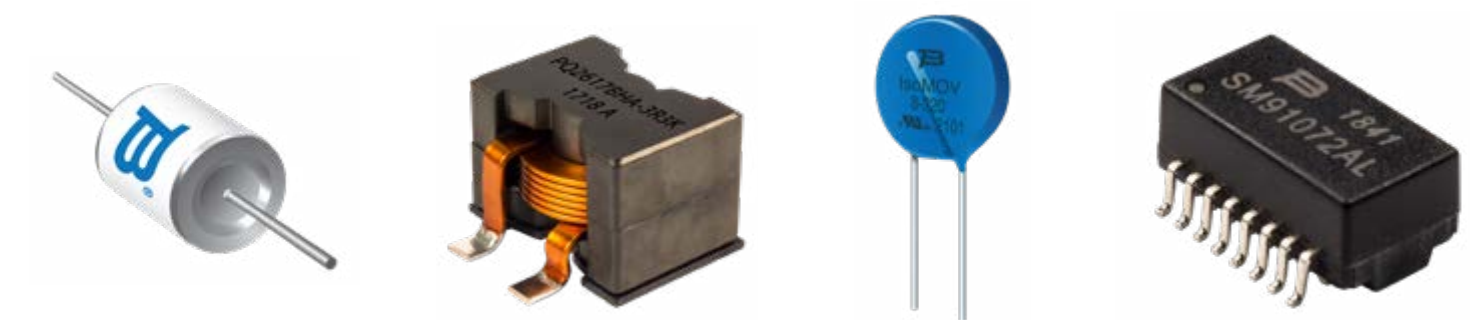

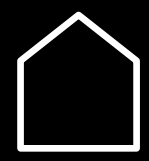

Built for harsh Environments. Designed with the Future in Mind.

The Standard Vitalis Buccaneer connectors combine proven performance with bio-based materials.

For decades, the Buccaneer connector has been a trusted name in power connectivity, known for its durability, reliability, and performance in demanding environments. Now, that legacy takes a meaningful step forward. The Standard Vitalis Buccaneer connector range has been thoughtfully re-engineered to reduce environmental impact – without compromising the performance engineers rely on.

Built on the same robust platform as the Standard Buccaneer, the Standard Vitalis range introduces bio-based plastics with up to 86 % bio-based content by weight, supporting sustainability goals while maintaining proven electrical and mechanical characteristics. This evolution reflects a growing demand for responsible design choices across industrial, agricultural, and marine applications.

Performance remains uncompromised. The Standard Vitalis range delivers ratings of up to 12 A and 277 V AC/DC, with configurations ranging from 2 to 25 contacts, making it suitable for a wide variety of power and signal requirements. Engineers can select from seven versatile body styles, including flex cable, inline cable, front and rear panel mount, PCB mount, bulkhead, and flange mount – offering design flexibility across new builds and retrofits alike.

Designed to thrive in harsh conditions, the Standard Vitalis range features IP68 and IP69K environmental sealing, ensuring protection against dust, immersion, and high-pressure washdown. These rugged connectors are ideal for applications exposed to moisture and extreme operating conditions, where reliability is critical and failure is not an option.

By combining decades of trusted Buccaneer performance with forward-looking materials innovation, the Standard Vitalis Buccaneer connector range enables engineers to make more sustainable choices – without redesigning systems or sacrificing reliability. It's the same connector you trust, re-imagined for a more responsible future.



[More information on arrow.com](#)

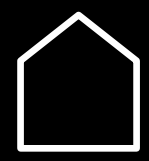

High Power Chip & Ceramic Resistors

WK73-Series

High Power Wide Terminal

KOA's wide terminal resistors offer several advantages compared to standard footprints.

For example, the 0612 chip size allows 6 x power rating compared to standard 1206 parts. This saves board space and is possible due to the improved heat dissipation via the solder joints.

The larger terminals also enhance terminal strength and the smaller distance between the terminals reduces expansion stress.

Finally, the inner resistive pattern is designed to minimize hotspots.

Features and Benefits

- Excellent heat dissipation characteristics
- Superior temperature and power cycling performance
- Higher rated power – less board space than standard chips
- Standard sizes 0204 ... 1225
- Resistance range 10 mΩ ... 1 MΩ
- AEC-Q200 qualified
- Anti-sulfuration type also available

Applications:

- Automotive electronics
- Power supplies
- Motor control units
- Industrial power control
- Battery packs

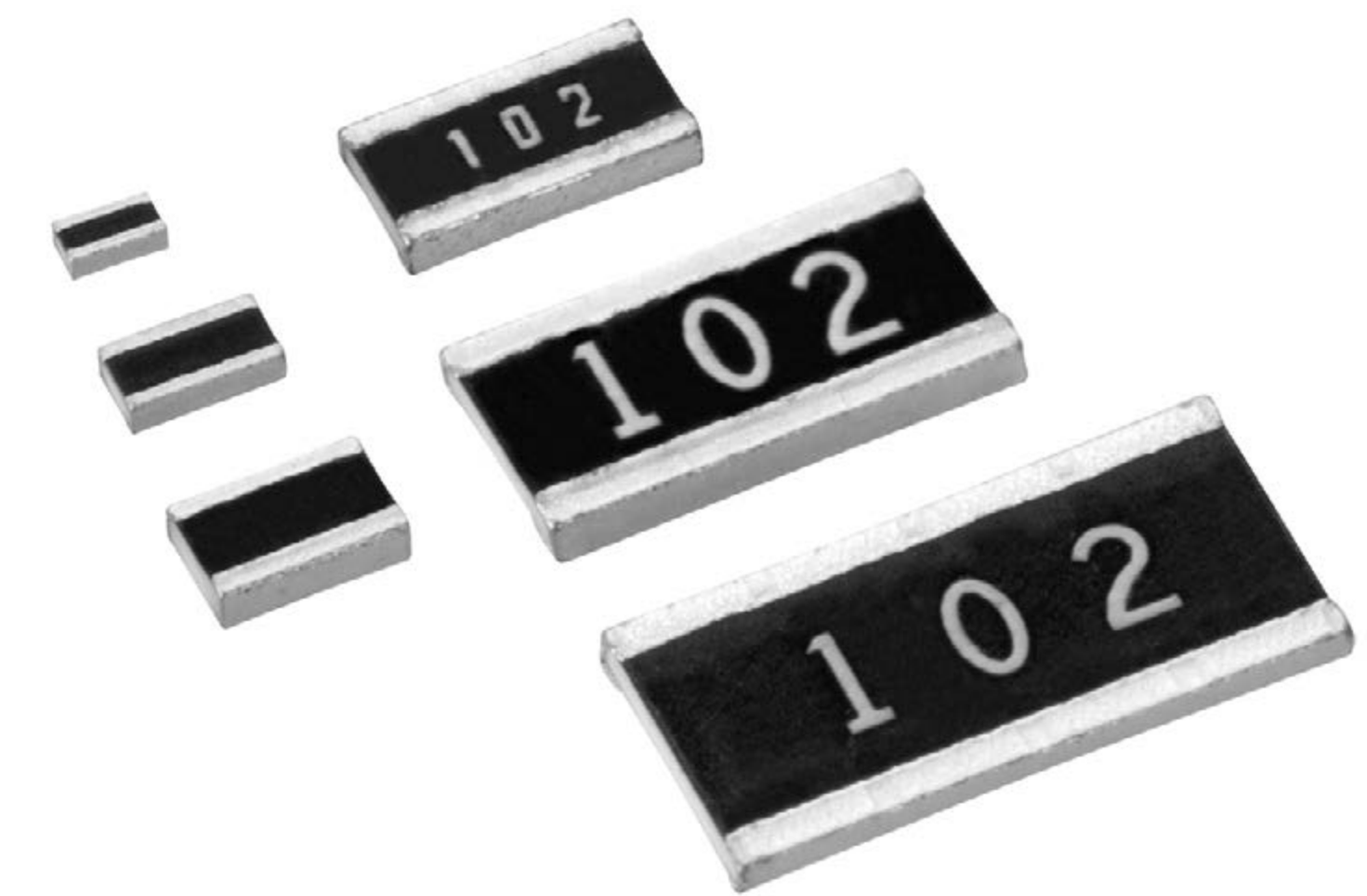

Orderable Part Series at arrow.com

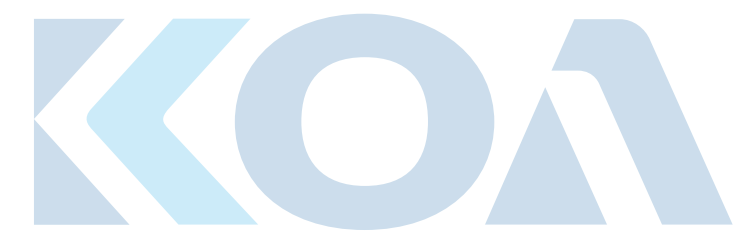
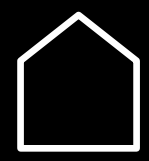

High Power Chip & Ceramic Resistors

WK73-Series

High Power Wide Terminal

KOA's wide terminal resistors offer several advantages compared to standard footprints.

For example, the 0612 chip size allows 6 x power rating compared to standard 1206 parts. This saves board space and is possible due to the improved heat dissipation via the solder joints.

The larger terminals also enhance terminal strength and the smaller distance between the terminals reduces expansion stress.

Finally, the inner resistive pattern is designed to minimize hotspots.

Features and Benefits

- Excellent heat dissipation characteristics
- Superior temperature and power cycling performance
- Higher rated power – less board space than standard chips
- Standard sizes 0204 ... 1225
- Resistance range 10 mΩ ... 1 MΩ
- AEC-Q200 qualified
- Anti-sulfuration type also available

Applications:

- Automotive electronics
- Power supplies
- Motor control units
- Industrial power control
- Battery packs

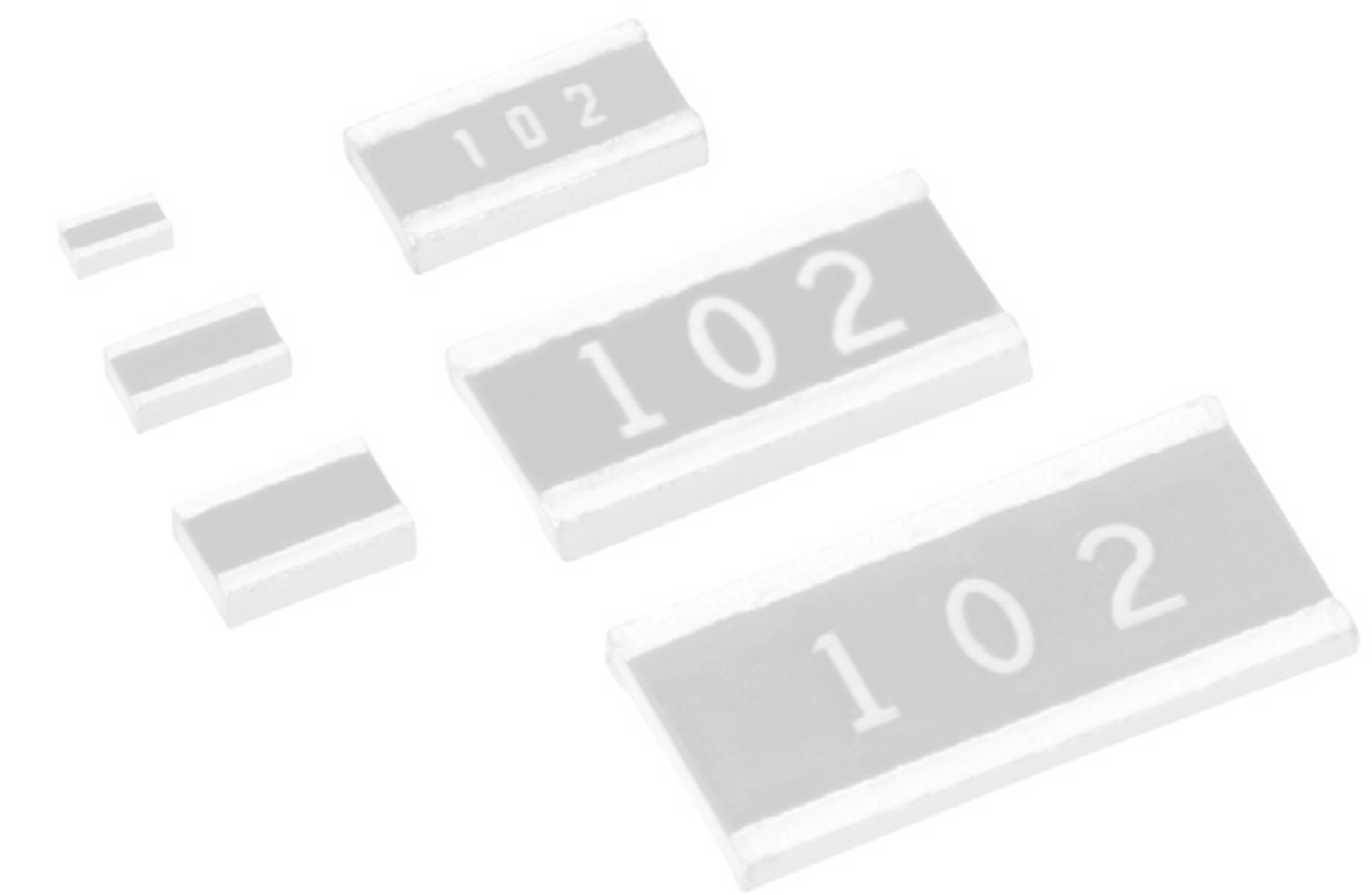

Orderable Part Series at arrow.com

- [WK73-Series](#)

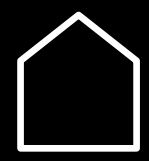

High Power Chip & Ceramic Resistors

HPC

Ceramic High Voltage Resistors

KOA's original bulk ceramic resistors don't use a resistive film or wire element – the whole body is the resistive element. This construction results in an extremely robust device, capable of absorbing high pulse currents and voltages.

Features & Benefits

- Solid ceramic resistor body ideal for HV and surge currents
- Non-inductive
- Up to 25 kV pulse voltage
- Power rating 1/2~5 W
- Operating temperatures - 40 ~ + 200 °C
- AEC-Q200 qualified
- EU-RoHS compliant
- PCF: Flame retardant coating (equivalent to UL94 V-0)

Applications:

- High voltage circuits
- Medical HV-products
- Power supplies
- Inrush current limiting
- Snubber circuits
- HV dividers
- X-ray generators
- Electron beam microscopes
- Replacement for solid carbon resistors

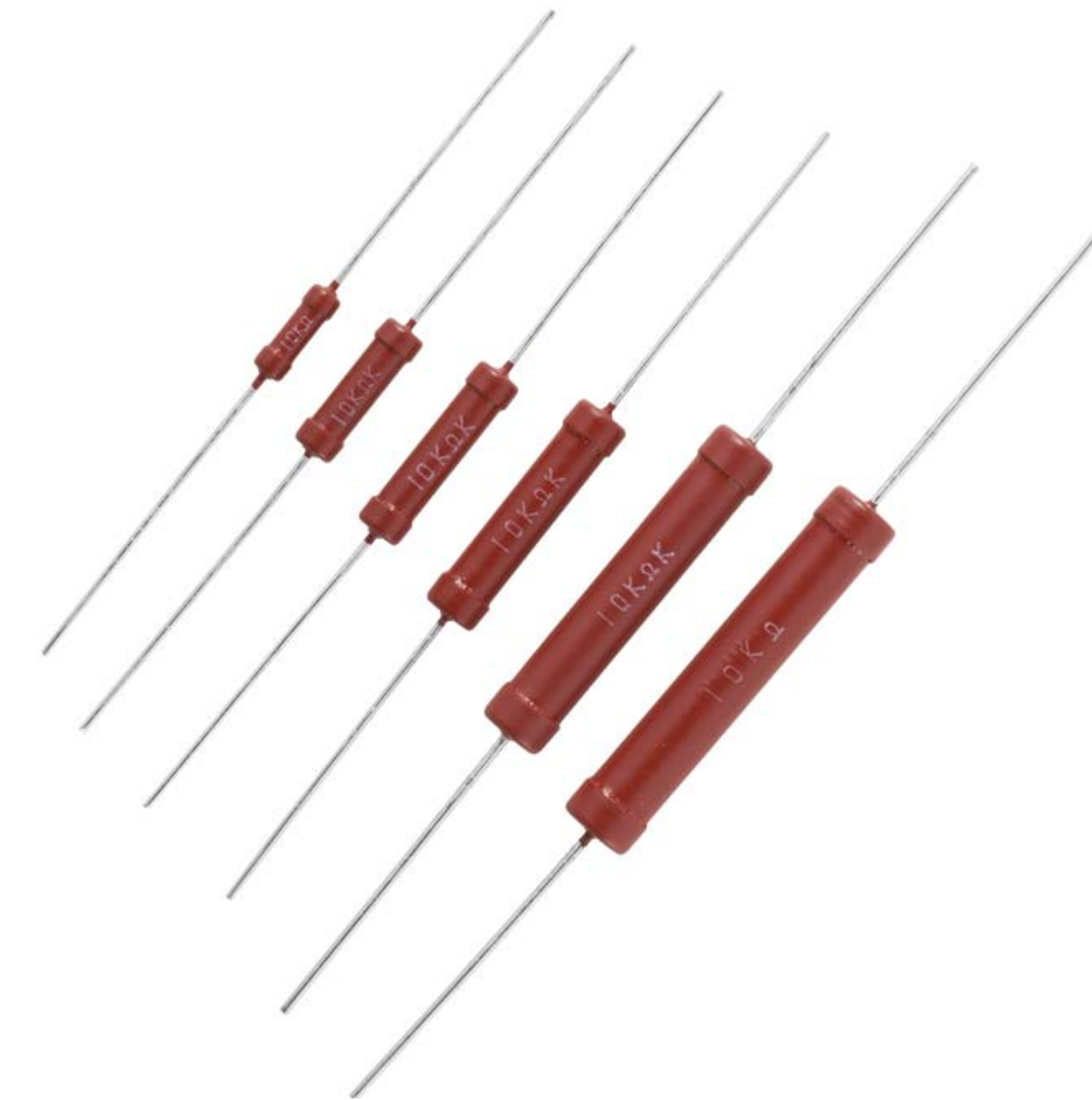

Orderable Part Series at arrow.com

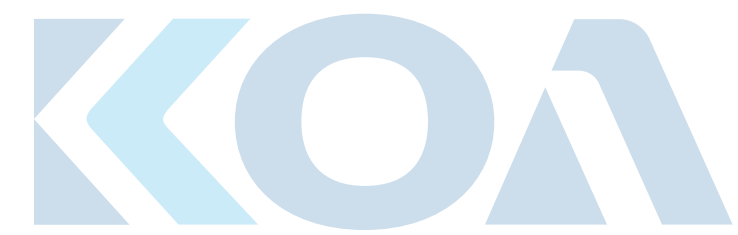
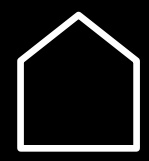

High Power Chip & Ceramic Resistors

HPC

Ceramic High Voltage Resistors

KOA's original bulk ceramic resistors don't use a resistive film or wire element – the whole body is the resistive element. This construction results in an extremely robust device, capable of absorbing high pulse currents and voltages.

Features & Benefits

- Solid ceramic resistor body ideal for HV and surge currents
- Non-inductive
- Up to 25 kV pulse voltage
- Power rating 1/2~5 W
- Operating temperatures - 40 ~ + 200 °C
- AEC-Q200 qualified
- EU-RoHS compliant
- PCF: Flame retardant coating (equivalent to UL94 V-0)

Applications:

- High voltage circuits
- Medical HV-products
- Power supplies
- Inrush current limiting
- Snubber circuits
- HV dividers
- X-ray generators
- Electron beam microscopes
- Replacement for solid carbon resistors

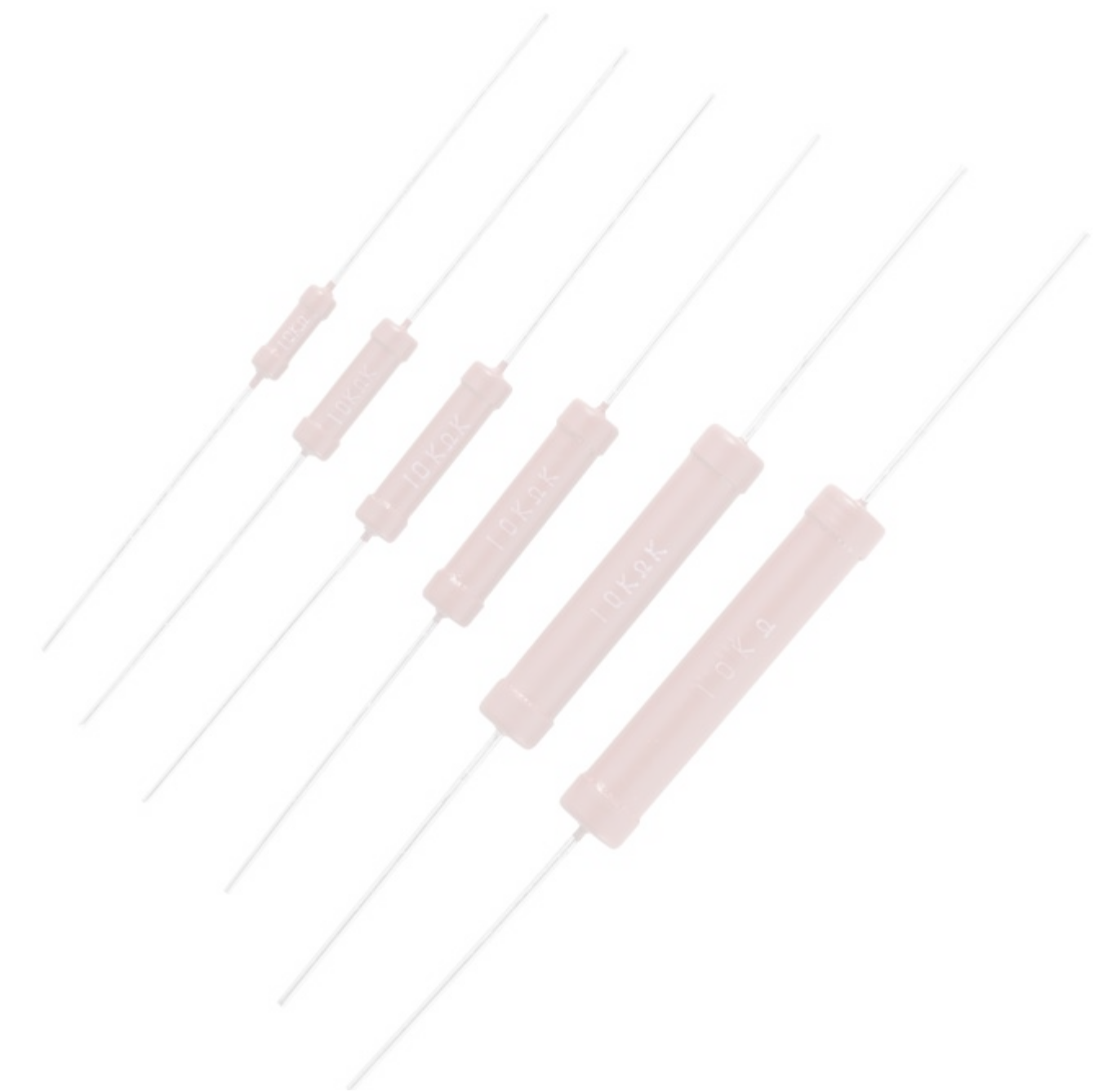

Orderable Part Series at arrow.com

- [HPC-Series](#)

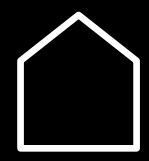

Littelfuse LS0502SCD33 eFuse

The LS0502SCD33 protection IC provides a complete solution designed for systems with backup storage capacitors or the capacitor bank. This integrated system implements essential features such as input overvoltage and overcurrent protection circuits, a reverse blocking switch, and a super capacitor charging control circuit.

The LS0502SCD33 is a complete solution for system with backup storage capacitor or capacitor bank. It integrates input overvoltage, overcurrent protection circuit, a reverse blocking switch and super capacitor charging control circuit. It also has built-in cell balance to provide protection over two cell super capacitor system.

When the main supply is present and above the minimum system supply voltage, system will draw power from input supply. At the same time, integrated linear charger charges the storage element at up to 300 mA current. Once the storage element is charged, the

circuit draws only 2.5 μ A of current while it maintains the super capacitor or other storage element in its ready state. When the main supply is removed, the integrated reverse blocking switch will block current flow from system rail to input. The linear charger will be turned on to provide power to system rail with low resistance path with up to 2 A current.

Integrated cell balancing circuit will keep monitoring the cell voltage when charging and keep the two cells voltage at same level.

The LS0502SCD33 is externally programmable for input current limit, input overvoltage, charge current limit, and charge voltage limit. It provides a flag signal when input supply is unplugged so that main system can taking action. LS0502SCD33 is available in DFN3X3-10 package.

Features and Benefits

- 3.3 V to 5.5 V System Voltage
- 18 V Input Rating with Overvoltage Protection
- Programmable 1.1 V to 5.3 V Cap Voltage Range
- Programmable Super Capacitor Charge Current
- Programmable Input Overcurrent Protection
- Automatic Cell Balancing
- Automatic Main/Backup Switchover
- Up to 2 A Discharge Current
- Programmable Voltage and Current Thresholds
- ± 2 % Threshold Accuracy
- 2.5 μ A Ready Quiescent Current
- Small Solution Size
- DFN Package

Applications

More information on arrow.com

Orderable Part Numbers at arrow.com

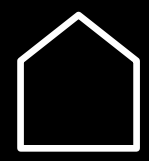

Littelfuse LS0502SCD33 eFuse

The LS0502SCD33 protection IC provides a complete solution designed for systems with backup storage capacitors or the capacitor bank. This integrated system implements essential features such as input overvoltage and overcurrent protection circuits, a reverse blocking switch, and a super capacitor charging control circuit.

The LS0502SCD33 is a complete solution for system with backup storage capacitor or capacitor bank. It integrates input overvoltage, overcurrent protection circuit, a reverse blocking switch and super capacitor charging control circuit. It also has built-in cell balance to provide protection over two cell super capacitor system.

When the main supply is present and above the minimum system supply voltage, system will draw power from input supply. At the same time, integrated linear charger charges the storage element at up to 300 mA current. Once the storage element is charged, the

circuit draws only 2.5 μ A of current while it maintains the super capacitor or other storage element in its ready state. When the main supply is removed, the integrated reverse blocking switch will block current flow from system rail to input. The linear charger will be turned on to provide power to system rail with low resistance path with up to 2 A current.

Integrated cell balancing circuit will keep monitoring the cell voltage when charging and keep the two cells voltage at same level.

The LS0502SCD33 is externally programmable for input current limit, input overvoltage, charge current limit, and charge voltage limit. It provides a flag signal when input supply is unplugged so that main system can taking action. LS0502SCD33 is available in DFN3X3-10 package.

Features and Benefits

- 3.3 V to 5.5 V System Voltage
- 18 V Input Rating with Overvoltage Protection
- Programmable 1.1 V to 5.3 V Cap Voltage Range
- Programmable Super Capacitor Charge Current
- Programmable Input Overcurrent Protection
- Automatic Cell Balancing



Applications

- Handheld Industrial Equipment
- Dash Camera
- IoT
- SmartMeter
- Portable Device with Removable Battery

[More information on arrow.com](#)

[Orderable Part Numbers at arrow.com](#)

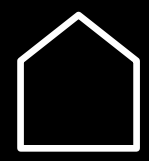

Littelfuse LS0502SCD33 eFuse

The LS0502SCD33 protection IC provides a complete solution designed for systems with backup storage capacitors or the capacitor bank. This integrated system implements essential features such as input overvoltage and overcurrent protection circuits, a reverse blocking switch, and a super capacitor charging control circuit.

The LS0502SCD33 is a complete solution for system with backup storage capacitor or capacitor bank. It integrates input overvoltage, overcurrent protection circuit, a reverse blocking switch and super capacitor charging control circuit. It also has built-in cell balance to provide protection over two cell super capacitor system.

When the main supply is present and above the minimum system supply voltage, system will draw power from input supply. At the same time, integrated linear charger charges the storage element at up to 300 mA current. Once the storage element is charged, the

circuit draws only 2.5 μ A of current while it maintains the super capacitor or other storage element in its ready state. When the main supply is removed, the integrated reverse blocking switch will block current flow from system rail to input. The linear charger will be turned on to provide power to system rail with low resistance path with up to 2 A current.

Integrated cell balancing circuit will keep monitoring the cell voltage when charging and keep the two cells voltage at same level.

The LS0502SCD33 is externally programmable for input current limit, input overvoltage, charge current limit, and charge voltage limit. It provides a flag signal when input supply is unplugged so that main system can taking action. LS0502SCD33 is available in DFN3X3-10 package.

Features and Benefits

- 3.3 V to 5.5 V System Voltage
- 18 V Input Rating with Overvoltage Protection
- Programmable 1.1 V to 5.3 V Cap Voltage Range
- Programmable Super Capacitor Charge Current
- Programmable Input Overcurrent Protection
- Automatic Cell Balancing
- Automatic Main/Backup Switchover
- Up to 2 A Discharge Current
- Programmable Voltage and Current Thresholds
- ± 2 % Threshold Accuracy
- 2.5 μ A Ready Quiescent Current
- Small Solution Size
- DFN Package

Applications



Orderable Part Numbers at arrow.com

- [LS0502SCD33](#)

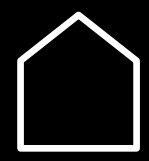

Lumberg Series 45

Electrical performance and mechanical robustness

Compact, robust, and flexible solutions for currents up to 90 A.

The increasing power requirements of new electronic systems present developers in all industries with the same challenge: transmitting high currents safely, spacesaving, and reliable transmission of high currents, while maintaining design freedom, ease of maintenance, and cost efficiency.

The series covers a wide range of applications – from industrial and process engineering to power distribution, automotive and battery storage applications.

The high-current contact sockets of the 45 series are characterized by low contact resistance (< 1 mΩ, depending on type). In combination with optimized contact geometries, this enables efficient current transmission with minimized self-heating.

Currents of up to 90 A can also be achieved with a 6-layer printed circuit board.

The contact technology of the 45 series is designed for mechanical robustness and high tolerance capability. Multiple spring contacts reduce the mechanical stress on the printed circuit boards and increase long-term reliability.

The products in Lumberg's 4580 series are available for flat connectors with a tab thickness of 0.5 mm to 2.0 mm and a tab width of 2.8 mm to 8 mm, depending on the type.

The 45 series meets the requirements of automotive standard LV 215, with tests including thermal aging, vibration resistance, friction corrosion, and electrical stress tests. The series also complies with standards DIN EN IEC 60068-2-82 and JEDEC JESD201A Class 2 for tin whiskers.

The product segment for high-current contacts is currently experiencing significant growth and is being strategically expanded. The existing Series 45 portfolio is currently being supplemented with silver-plated variants and THT-compatible versions to specifically address additional applications and customer requirements.

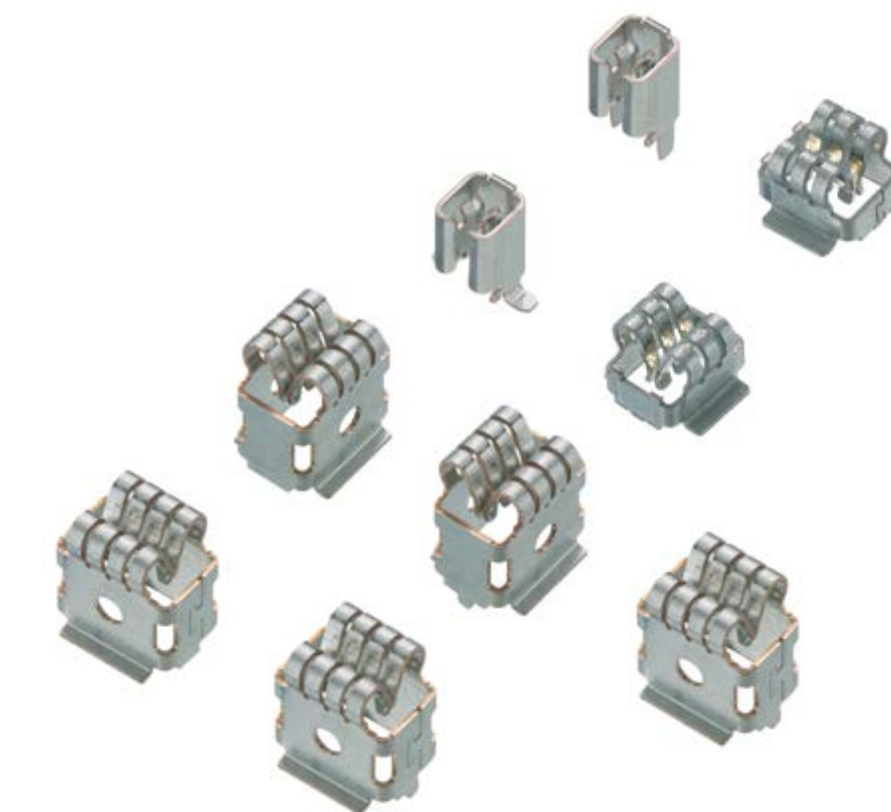

[More information on arrow.com](#)

[Orderable Part Numbers at arrow.com](#)

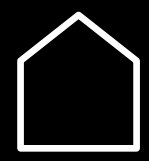

Lumberg Series 45

Electrical performance and mechanical robustness

Compact, robust, and flexible solutions for currents up to 90 A.

The increasing power requirements of new electronic systems present developers in all industries with the same challenge: transmitting high currents safely, spacesaving, and reliable transmission of high currents, while maintaining design freedom, ease of maintenance, and cost efficiency.

The series covers a wide range of applications – from industrial and process engineering to power distribution, automotive and battery storage applications.

The high-current contact sockets of the 45 series are characterized by low contact resistance (< 1 mΩ, depending on type). In combination with optimized contact geometries, this enables efficient current transmission with minimized self-heating.

Currents of up to 90 A can also be achieved with a 6-layer printed circuit board.

The contact technology of the 45 series is designed for mechanical robustness and high tolerance capability. Multiple spring contacts reduce the mechanical stress on the printed circuit boards and increase long-term reliability.

The products in Lumberg's 4580 series are available for flat connectors with a tab thickness of 0.5 mm to 2.0 mm and a tab width of 2.8 mm to 8 mm, depending on the type.

The 45 series meets the requirements of automotive standard LV 215, with tests including thermal aging, vibration resistance, friction corrosion, and electrical stress tests. The series also complies with standards DIN EN IEC 60068-2-82 and JEDEC JESD201A Class 2 for tin whiskers.

The product segment for high-current contacts is currently experiencing significant growth and is being strategically expanded. The existing Series 45 portfolio is currently being supplemented with silver-plated variants and THT-compatible versions to specifically address additional applications and customer requirements.

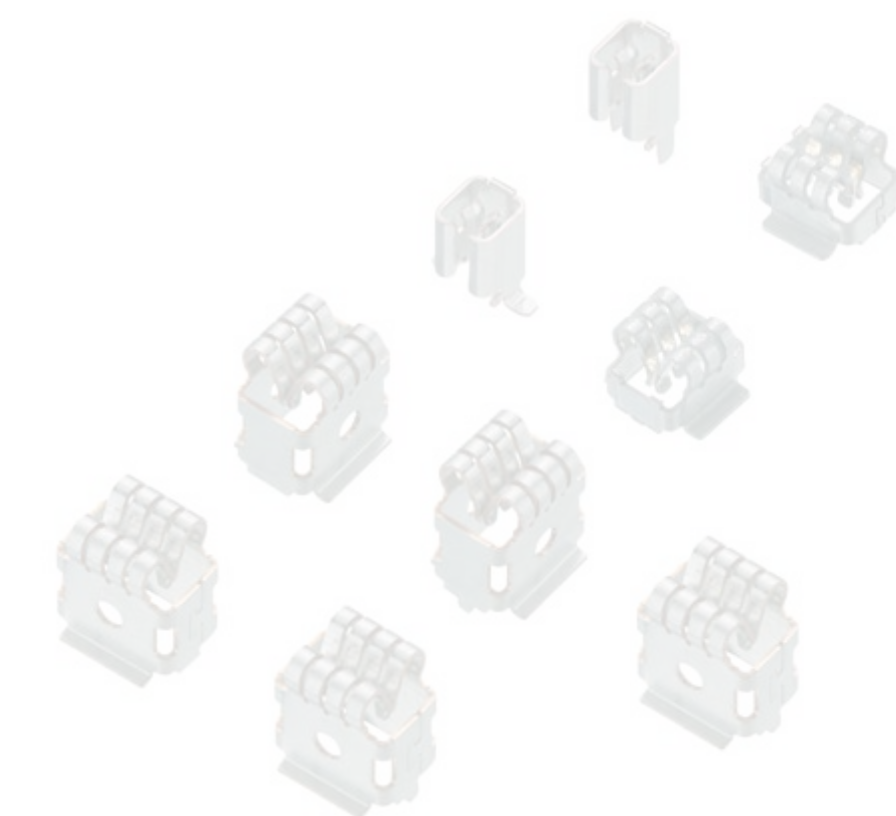

Orderable Part Series at arrow.com

- [4580 03 MP T0,8 V12VP12](#)

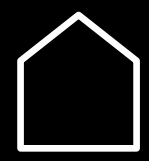

Compact power interconnects for high voltage and high current applications

As power densities continue to increase in heat pumps, energy distribution systems and industrial equipment, connectors are becoming safety-critical design elements. Engineers need solutions that reliably carry high currents, remain thermally stable and enable efficient, cost-effective assembly.

The RAST 7.5 Power system from Lumberg Connect has been developed specifically to meet these requirements. It combines robust mechanics, standards compliance and easy processing in a compact interconnect solution for demanding power applications. Silver-plated contacts, generous insulation distances and proven IDT termination technology ensure low contact resistance, high process reliability and long service life – even in harsh environments.

Key performance features and benefits:

- Up to 25 A current rating – reliable high-power transmission without overheating
- 500 V AC rated voltage – ideal for modern energy and power modules
- Up to 1,000 V (VDE, pollution degree 2) with Lumberg's dedicated high-voltage material variant
- 5.7 mm creepage and clearance distances – enhanced electrical safety and standards compliance
- CTI ≥ 600 , insulation resistance $> 10 \text{ G}\Omega$ – dependable insulation under moisture and contamination
- Silver-plated CuNiSi contacts – low losses and stable long-term contact performance
- IDT termination – solder-free, fast, repeatable and automation-ready assembly
- Locking mechanism and UL 94 V-0 housing material – vibration- and flameresistant

- Operating range $-40 \text{ }^\circ\text{C}$ to $+130 \text{ }^\circ\text{C}$ – suitable for thermally demanding environments
- 2 to 5 positions, modular combination without pitch loss – flexible integration into compact designs

Conclusion: RAST 7.5 Power delivers high electrical performance, easy processing and maximum reliability – a future-proof interconnect solution for high-current and high-voltage applications.

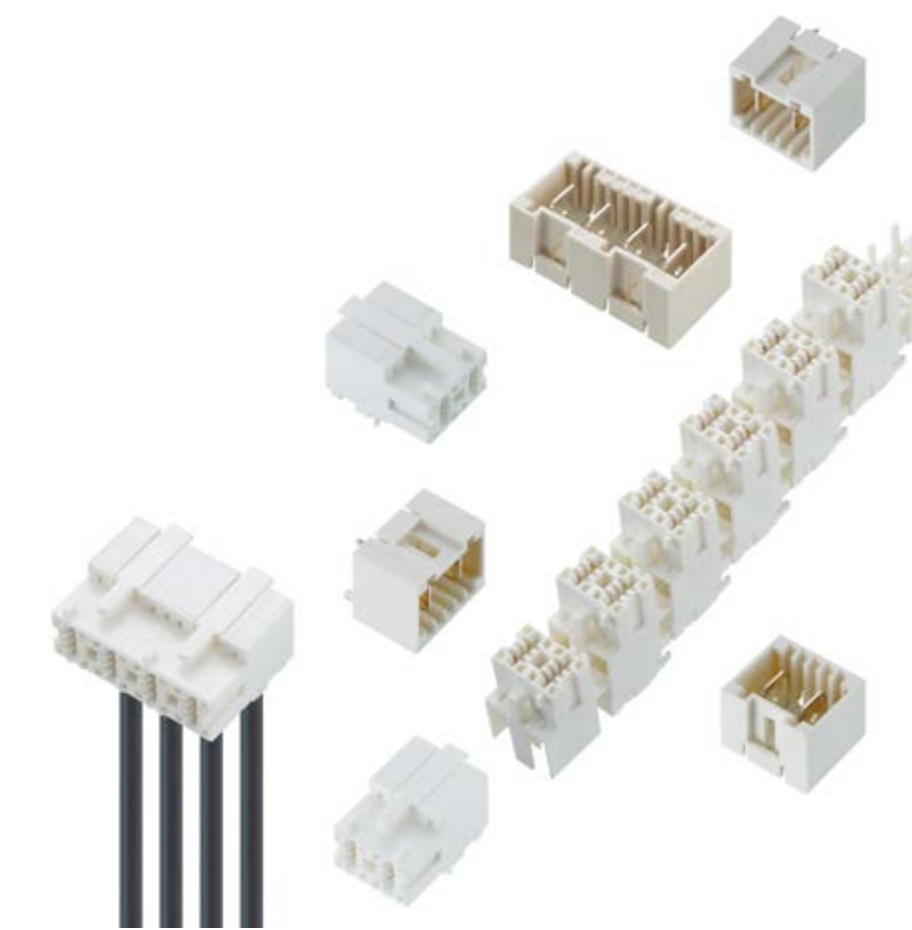

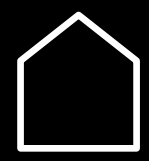

High-Power Reliability for Demanding Designs

NIC Components Thick-Film & Thin-Film Resistor Solutions

NIC Components offers a broad portfolio of high-power chip resistors built to withstand harsh electrical, thermal, and environmental stresses for today's most demanding designs.

NRCPA provides exceptional pulse-energy endurance and robust electrical performance for circuits exposed to frequent transients. Applications include metering, industrial controls, medical/diagnostic equipment, and test and measurement systems.

NRCAH delivers ultra-high-power capability with automotive-grade robustness for environments requiring maximum power density. Ideal for automotive electronics, industrial power systems, high-load circuits, and thermal-stress conditions.

NTRWH offers thin-film precision with advanced environmental durability, including high-temperature operation and

sulfur resistance. Common uses include automotive sensing modules, medical instrumentation, industrial sensors, and precision measurement circuits.

NCSQ supports ultra-low resistance values with high current capability and excellent thermal stability for modern power-management designs. Applications include high-power current sensing, BMS, motor drives, DC/DC converters, and EV power electronics.

To complete high-power designs, NIC offers an ecosystem of supporting passives engineered to work seamlessly with these resistor families. Designers can pair them with NIC's high-performance power inductors, such as NPMG low-loss molded inductors and NPIM_PA high-current AEC-Q200 series, along with hybrid-polymer, ceramic, aluminum electrolytic, and tantalum capacitors for filtering, decoupling, and energy storage. NIC also provides robust

circuit-protection solutions – including TVS diodes, fuses, and ESD suppressors – plus NTRx thin-film resistors for ultra-stable, low-noise control networks. Together, these complementary components enable engineers to build complete, reliable power-management, sensing, and protection architectures that fully leverage the strength of NIC's high-power resistor technologies.

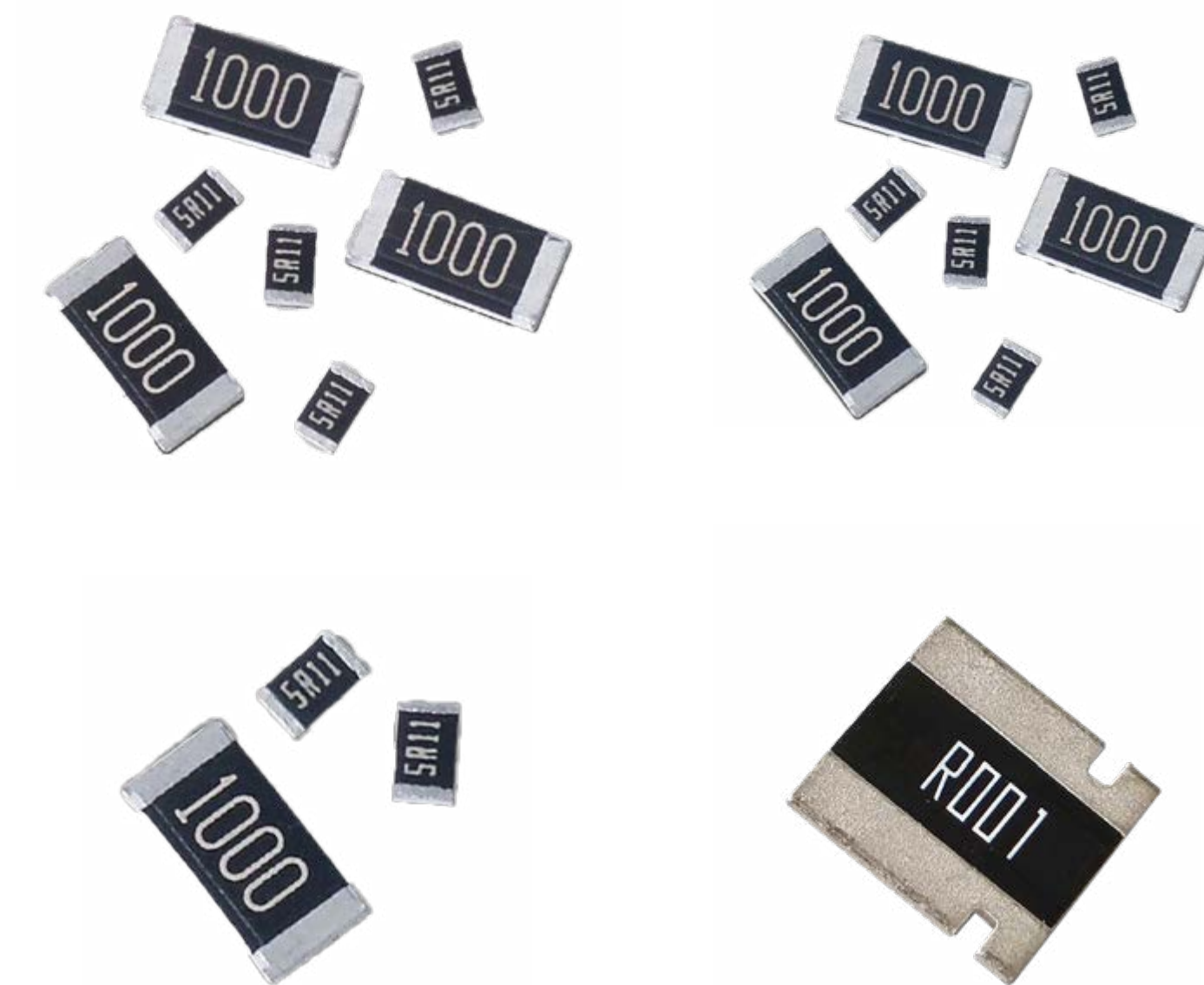

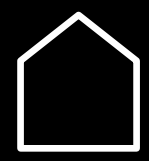

High Power Resistive and Thermal Solutions from Ohmite

Ohmite's power resistors have led the industry in product innovation for over 100 years. We offer multiple product types to suit specific application requirements. From surface mount components to large load banks, Ohmite carries the products required for your application.

Ohmite has multiple part series for High Power, Surge, Current Sense and other applications. Part constructions range from thick film to wirewound. With multiple mounting options and constructions, you're sure to find the proper High Power resistor required to fit your needs.

Many of our High Power resistors can be attached to a heat sink for enhanced power dissipation. Much smaller than standard parts of the same wattage, Heat Sinkable resistors release most of their heat in one plane. The single side is attached to a heat sink, and the heat

generated is absorbed. Once the heat is absorbed, it is released into the air or water through a heat sink or chill plate.

High Current/Braking

Ohmite understands the demand for high current and braking applications. We provide quality high current products for load testing and dynamic braking resistors in the transportation and semiconductor industries. Thanks to the products' modular and scalable designs, customers can confidently find

the proper high current/braking resistor required to fit their needs for motor deceleration and other applications.

Our high current resistors cover applications ranging from standard current loads to motor braking for trains and elevators. Other typical applications include: battery testing, current detection in precise power sources, constant current sources, industrial power conversion circuits, HEVs, fuel cells and constant electronic loads.

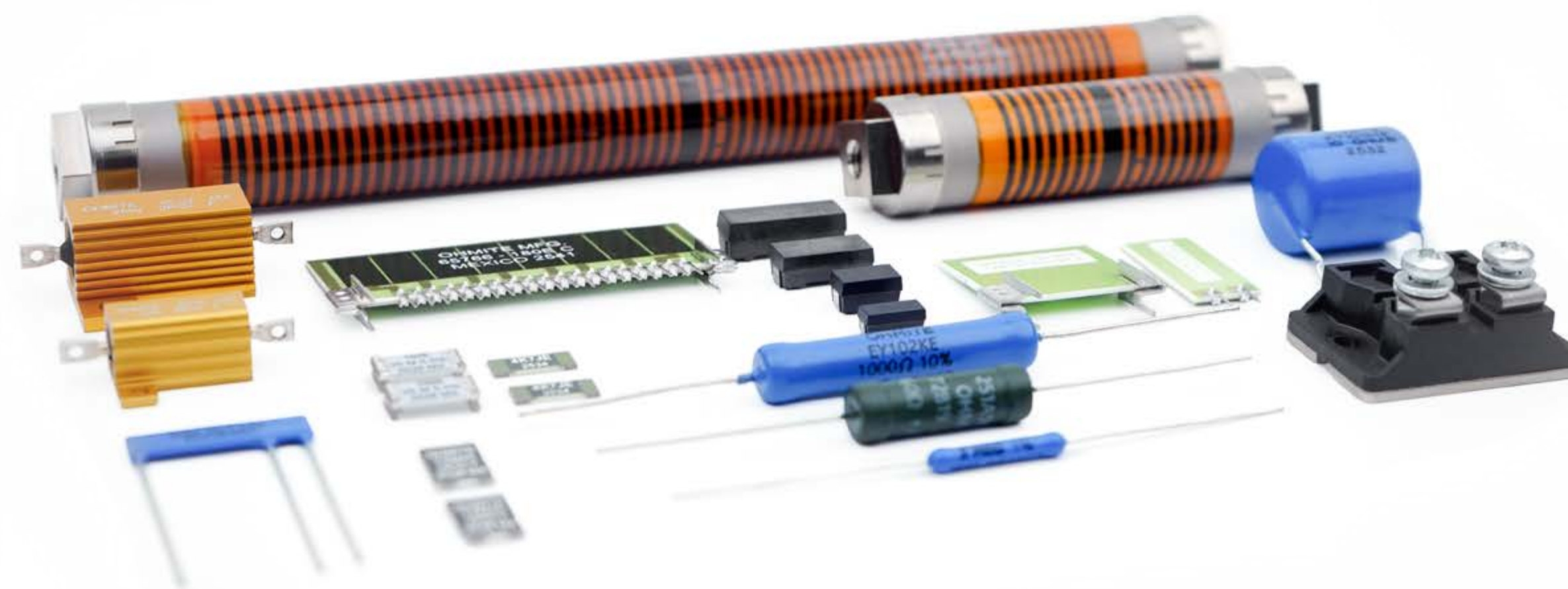

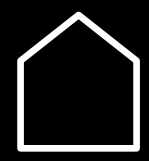

VeriSafe Absence of Voltage Tester

Introducing the VeriSafe™ Absence of Voltage Tester: The Safe Way to Verify the Absence of Voltage

When servicing electrical equipment, worker safety is paramount. One of the critical safety requirements for de-energized work is verifying the absence of voltage to confirm an electrically safe environment. Traditional testing methods with handheld devices can be time-consuming, complex, and expose workers to unnecessary risks. VeriSafe Absence of Voltage Tester, a revolutionary solution from Panduit, automates this essential process, ensuring safety, reliability, and efficiency.

With VeriSafe, workers can verify the absence of voltage with the push of a button, reducing both the risk of exposure to electrical hazards and the time spent on manual testing.

Designed in accordance with the NFPA 70E standard, the VeriSafe Absence of Voltage Tester helps ensure compliance with safety regulations and simplifies the lockout/tagout procedure.

This innovative system also reduces human error, making it easier than ever to establish an electrically safe work condition.

By automating the test sequence, VeriSafe protects workers and improves productivity, delivering a clear, visual confirmation when it is safe to proceed. Whether you're working on three-phase circuits or single-phase systems, this reliable and fail-safe tester is an indispensable tool for electrical maintenance and safety.

Features

- Efficiency: Test results available within 10 seconds with one button.
- Voltage Detection: 600 V or 1000 V
- Absence of Voltage Threshold: 3 V
- Voltage Presence Indicators: AC & DC
- Power: 3.6 V Battery powered or DC Power Supply

Benefits

- Improved Process Safety: Minimized human error
- Productivity: Reduced labor costs
- User-Friendly: Simple and quick operation by trained personnel
- Versatile Applications: Data centers, Control panels, industrial and commercial facilities, motor control and automation
- Reliable Test Results: Fail-Safe system



[More information on arrow.com](#)

[Orderable Part Number at arrow.com](#)

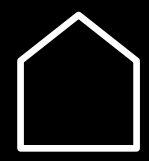

VeriSafe Absence of Voltage Tester

Introducing the VeriSafe™ Absence of Voltage Tester: The Safe Way to Verify the Absence of Voltage

When servicing electrical equipment, worker safety is paramount. One of the critical safety requirements for de-energized work is verifying the absence of voltage to confirm an electrically safe environment. Traditional testing methods with handheld devices can be time-consuming, complex, and expose workers to unnecessary risks. VeriSafe Absence of Voltage Tester, a revolutionary solution from Panduit, automates this essential process, ensuring safety, reliability, and efficiency.

With VeriSafe, workers can verify the absence of voltage with the push of a button, reducing both the risk of exposure to electrical hazards and the time spent on manual testing.

Designed in accordance with the NFPA 70E standard, the VeriSafe Absence of Voltage Tester helps ensure compliance with safety regulations and simplifies the lockout/tagout procedure.

This innovative system also reduces human error, making it easier than ever to establish an electrically safe work condition.

By automating the test sequence, VeriSafe protects workers and improves productivity, delivering a clear, visual confirmation when it is safe to proceed. Whether you're working on three-phase circuits or single-phase systems, this reliable and fail-safe tester is an indispensable tool for electrical maintenance and safety.

Features

- Efficiency: Test results available within 10 seconds with one button.
- Voltage Detection: 600 V or 1000 V
- Absence of Voltage Threshold: 3 V
- Voltage Presence Indicators: AC & DC
- Power: 3.6 V Battery powered or DC Power Supply

Benefits

- Improved Process Safety: Minimized human error
- Productivity: Reduced labor costs
- User-Friendly: Simple and quick operation by trained personnel
- Versatile Applications: Data centers, Control panels, industrial and commercial facilities, motor control and automation
- Reliable Test Results: Fail-Safe system

The image shows a promotional banner for the VeriSafe Absence of Voltage Tester. It features the Panduit logo, a yellow circular device, and a yellow tagout label. The text reads "VeriSafe™ Simplify absence of voltage testing". Below the banner is a blue bar with the text "Orderable Part Series at arrow.com" and a list of part numbers: "• VS-AVT".

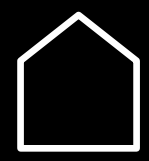

VeriSafe Absence of Voltage Tester

Introducing the VeriSafe™ Absence of Voltage Tester: The Safe Way to Verify the Absence of Voltage



The banner features a yellow VeriSafe 2.0 AVT device on the left, a yellow instruction card below it, and the VeriSafe logo on the right. The text 'Simplify absence of voltage testing' is prominently displayed in the center-right.

PANDUIT VeriSafe™

Simplify absence of voltage testing

VeriSafe™

Simplify absence of voltage testing

Designed in accordance with the NFPA 70E standard, the VeriSafe Absence of Voltage Tester helps ensure compliance with safety regulations and simplifies the lockout/tagout procedure.

- Voltage Presence Indicators, AC & DC
- Power: 3.6 V Battery powered or DC Power Supply

Orderable Part Number at arrow.com

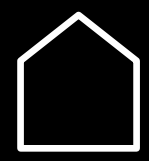

Simplifying AC Power Delivery with Pre-Assembled Cables

Manufacturer-built cable assemblies reduce cost, risk and complexity in AC power systems

When delivering power to a PCB, power connectors are only part of the story. The real performance of an AC power connection is defined by how reliably the connector, cable and termination work together over time. For many engineers, that is where pre-assembled cable solutions deliver real value.

Samtec's MMSD AC power cable assemblies are part of the Mini Mate® family and are designed to remove complexity from power system design. Rather than sourcing connectors, wire, tooling and test equipment separately, engineers can specify a complete, ready-to-use cable assembly that arrives fully terminated, tested and qualified by the original manufacturer.

Building AC power cables in-house requires more than components. Crimp tooling must be purchased and

maintained, operators must be trained, and test equipment must be calibrated and managed. For small production runs, prototypes or early development work, those costs can quickly outweigh the cost of the cable itself. Pre-assembled MMSD cables allow engineers to avoid that investment entirely.

Because MMSD cable assemblies are manufactured by Samtec using genuine tooling and controlled processes, customers also benefit from the full expertise of the original connector designer. Every termination meets the required electrical and mechanical performance, helping to reduce risk in power-critical applications.

For low to medium volumes, prototyping and fast-moving designs, pre-assembled AC power cables offer a faster path to market, predictable quality and

simplified procurement. With MMSD cable assemblies, Samtec makes it easier to integrate robust AC power connections without compromise.

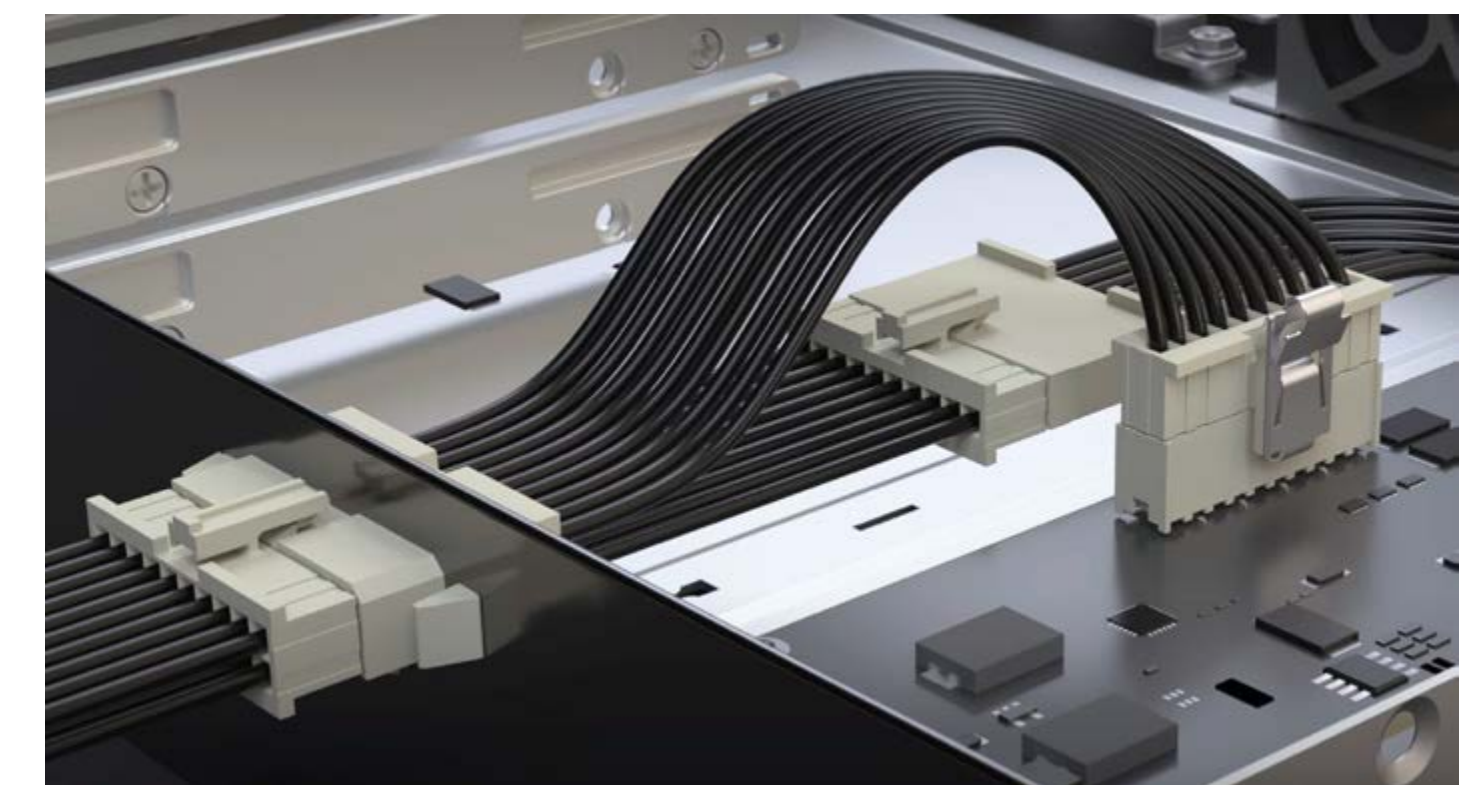

[Free Samples – order here](#)

[More information on arrow.com](#)

[Explore the Range at arrow.com](#)

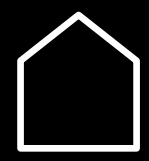

Simplifying AC Power Delivery with Pre-Assembled Cables

Manufacturer-built cable assemblies reduce cost, risk and complexity in AC power systems

When delivering power to a PCB, power connectors are only part of the story. The real performance of an AC power connection is defined by how reliably the connector, cable and termination work together over time. For many engineers, that is where pre-assembled cable solutions deliver real value.

Samtec's MMSD AC power cable assemblies are part of the Mini Mate[®] family and are designed to remove complexity from power system design. Rather than sourcing connectors, wire, tooling and test equipment separately, engineers can specify a complete, ready-to-use cable assembly that arrives fully terminated, tested and qualified by the original manufacturer.

Building AC power cables in-house requires more than components. Crimp tooling must be purchased and

maintained, operators must be trained, and test equipment must be calibrated and managed. For small production runs, prototypes or early development work, those costs can quickly outweigh the cost of the cable itself. Pre-assembled MMSD cables allow engineers to avoid that investment entirely.

Because MMSD cable assemblies are manufactured by Samtec using genuine tooling and controlled processes, customers also benefit from the full expertise of the original connector designer. Every termination meets the required electrical and mechanical performance, helping to reduce risk in power-critical applications.

For low to medium volumes, prototyping and fast-moving designs, pre-assembled AC power cables offer a faster path to market, predictable quality and

simplified procurement. With MMSD cable assemblies, Samtec makes it easier to integrate robust AC power connections without compromise.

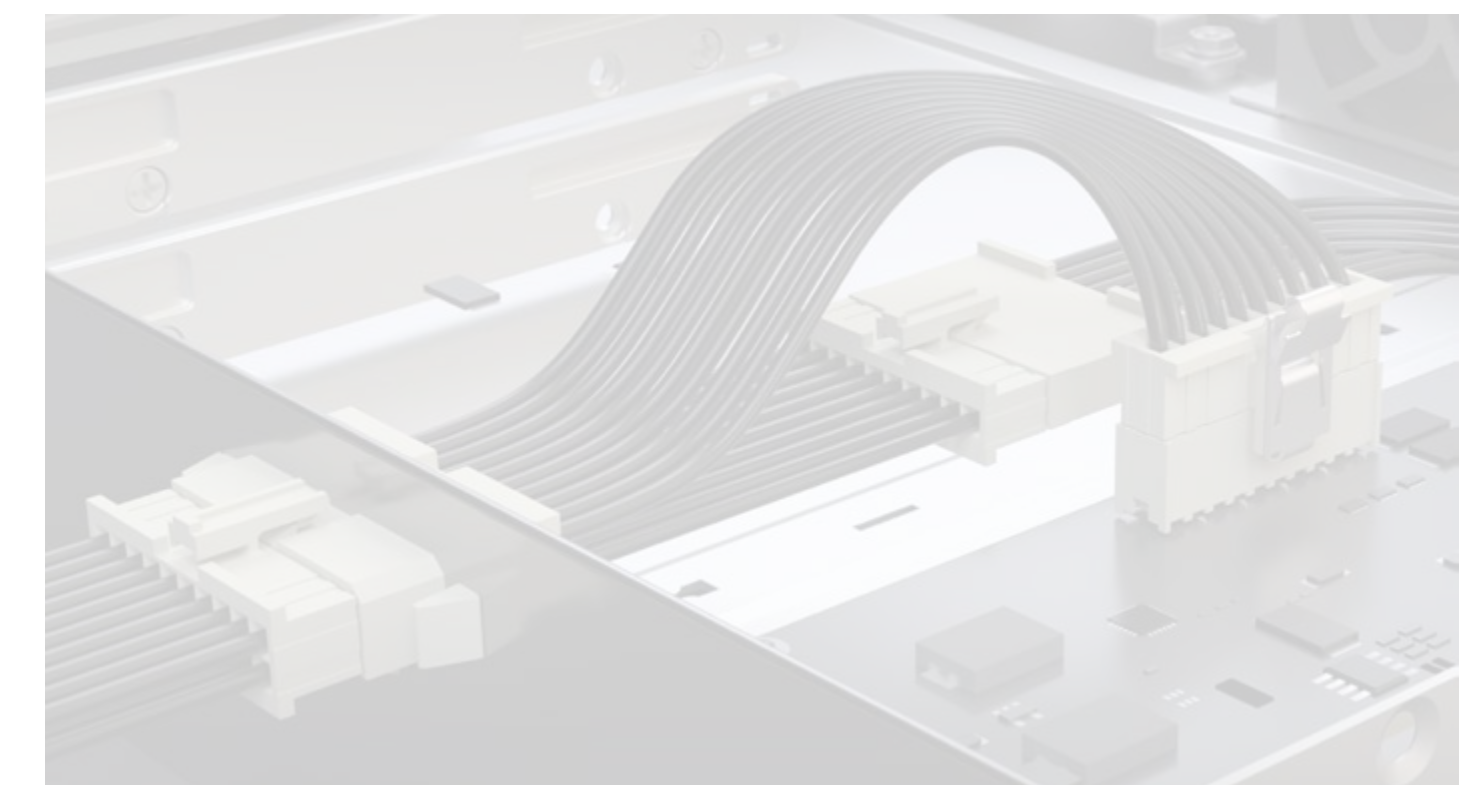

[Free Samples – order here](#)



[Explore the Range at arrow.com](#)

- [Samtec MMSD](#)

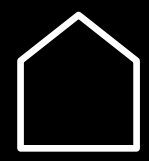

Susumu's High Power Resistor Portfolio

Enabling Next-Generation Power Electronics

With AEC-Q200 qualified thin film chip resistors and metal alloy shunts, Susumu enables designers to meet demanding high power application requirements.

Susumu's PRG and HRG series are precise thin film resistors with high power capability. The PRG series (long-side terminal) offers power ratings from 0.5 W to 3 W across sizes 1206, 2010, and 2512. The HRG series (short-side terminal) provides 1.0 W power rating in the compact 1206 size. Both series deliver exceptional precision with $\pm 0.1\%$ tolerance and low ± 25 ppm/ $^{\circ}\text{C}$ temperature coefficient. AEC-Q200 qualified with inherent anti-sulfuration properties and exceptional long-term stability, they are ideal for harsh automotive and industrial environments.

Susumu's metal alloy current sensing shunts are engineered with alloy technology and vacuum electron beam welding. The MSR series features resistance from 0.1 m Ω to

5 m Ω with proprietary "trimming-free" manufacturing that ensures uniform current distribution without hot spots, minimizing thermoelectric EMF effects. The MSRPM1216 delivers 7 W–10 W power handling with ± 100 ppm/ $^{\circ}\text{C}$ TCR in a 4-terminal configuration for precision applications, while the MSRPM2726 offers a superior TCR of $\pm 75/\pm 100$ ppm/ $^{\circ}\text{C}$. The MBRAS6918 series is specifically engineered for large-current sensing, capable of continuous operation at 500 A–700 A with 25 W power dissipation.

Its special heat treatment process achieves exceptional linearity with minimal resistance changes under varying currents, while withstanding pulse currents several times higher than rated values. With AEC-Q200 qualification, these shunts provide accurate high-frequency sensing across -55 $^{\circ}\text{C}$ to $+170$ $^{\circ}\text{C}$ for critical applications in EV battery management systems, motor control, etc.



Series	Resistance	Power	Current	TCR
MSRPM5930	0.1-1.0 m Ω	9-16 W	Up to 387 A	± 100 ppm/ ± 150 ppm/ $^{\circ}\text{C}$
MSRPM2726	0.2-1 m Ω	7-12 W	Up to 240 A	$\pm 50/\pm 75$ ppm/ $^{\circ}\text{C}$
MBRAS6918	50-100 $\mu\Omega$	25 W	500-700 A	± 100 -200 ppm/ $^{\circ}\text{C}$

Applications

[More information on arrow.com](#)

[Orderable Part Numbers at arrow.com](#)

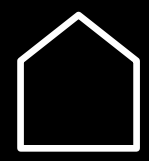

Susumu's High Power Resistor Portfolio

Enabling Next-Generation Power Electronics

With AEC-Q200 qualified thin film chip resistors and metal alloy shunts, Susumu enables designers to meet demanding high power application requirements.

Susumu's PRG and HRG series are precise thin film resistors with high power capability. The PRG series (long-side terminal) offers power ratings

5 mΩ with proprietary "trimming-free" manufacturing that ensures uniform current distribution without hot spots, minimizing thermoelectric EMF effects. The MSRPM1216 delivers 7 W–10 W power handling with ±100 ppm/°C TCR in a 4-terminal configuration for precision applications, while the MSRPM2726 offers a superior TCR of

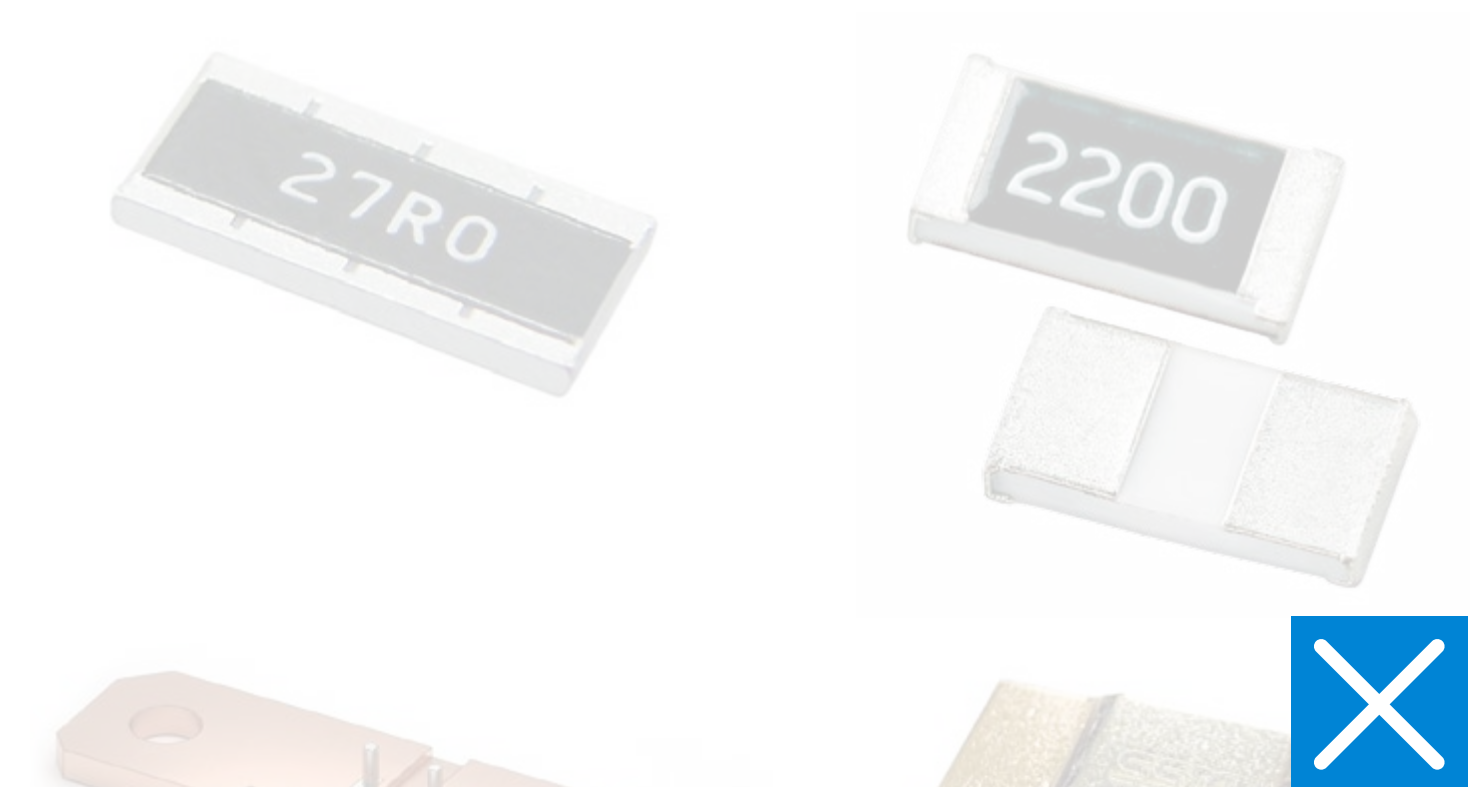

Series	Resistance	Power	Current	TCR
MSRPM5930	0.1-1.0 mΩ	9-16 W	Up to 387 A	±100 ppm/±150 ppm/°C
MSRPM2726	0.2-1 mΩ	7-12 W	Up to 240 A	±50/±75 ppm/°C
MBRAS6918	50-100 μΩ	25 W	500-700 A	±100-200 ppm/°C

properties and exceptional long-term stability, they are ideal for harsh automotive and industrial environments.

Susumu's metal alloy current sensing shunts are engineered with alloy technology and vacuum electron beam welding. The MSR series features resistance from 0.1 mΩ to

minimal resistance changes under varying currents, while withstanding pulse currents several times higher than rated values. With AEC-Q200 qualification, these shunts provide accurate high-frequency sensing across -55 °C to +170 °C for critical applications in EV battery management systems, motor control, etc.

[Applications](#)

[More information on arrow.com](#)

[Orderable Part Numbers at arrow.com](#)

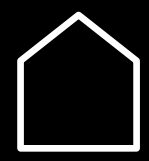

Susumu's High Power Resistor Portfolio

Enabling Next-Generation Power Electronics

With AEC-Q200 qualified thin film chip resistors and metal alloy shunts, Susumu enables designers to meet demanding high power application requirements.

Susumu's PRG and HRG series are precise thin film resistors with high power capability. The PRG series (long-side terminal) offers power ratings from 0.5 W to 3 W across sizes 1206, 2010, and 2512. The HRG series (short-side terminal) provides 1.0 W power rating in the compact 1206 size. Both series deliver exceptional precision with $\pm 0.1\%$ tolerance and low ± 25 ppm/ $^{\circ}\text{C}$ temperature coefficient. AEC-Q200 qualified with inherent anti-sulfuration properties and exceptional long-term stability, they are ideal for harsh automotive and industrial environments.

Susumu's metal alloy current sensing shunts are engineered with alloy technology and vacuum electron beam welding. The MSR series features resistance from 0.1 m Ω to

5 m Ω with proprietary "trimming-free" manufacturing that ensures uniform current distribution without hot spots, minimizing thermoelectric EMF effects. The MSRPM1216 delivers 7 W–10 W power handling with ± 100 ppm/ $^{\circ}\text{C}$ TCR in a 4-terminal configuration for precision applications, while the MSRPM2726 offers a superior TCR of $\pm 75/\pm 100$ ppm/ $^{\circ}\text{C}$. The MBRAS6918 series is specifically engineered for large-current sensing, capable of continuous operation at 500 A–700 A with 25 W power dissipation.

Its special heat treatment process achieves exceptional linearity with minimal resistance changes under varying currents, while withstanding pulse currents several times higher than rated values. With AEC-Q200 qualification, these shunts provide accurate high-frequency sensing across -55°C to $+170^{\circ}\text{C}$ for critical applications in EV battery management systems, motor control, etc.



Applications

- Automotive electronics (HVAC, EPS, BMS, OBC, Lamps)
- DC-DC & AC-DC converters
- Motor drives & inverters
- Industrial control systems
- Power supply units
- EV charging infrastructure
- Robotics
- Precision instrumentation
- Medical equipment

[More information on arrow.com](#)

[Orderable Part Numbers at arrow.com](#)

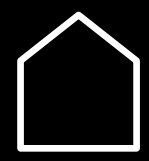

Susumu's High Power Resistor Portfolio

Enabling Next-Generation Power Electronics

With AEC-Q200 qualified thin film chip resistors and metal alloy shunts, Susumu enables designers to meet demanding high power application requirements.

Susumu's PRG and HRG series are precise thin film resistors with high power capability. The PRG series (long-side terminal) offers power ratings from 0.5 W to 3 W across sizes 1206, 2010, and 2512. The HRG series (short-side terminal) provides 1.0 W power rating in the compact 1206 size. Both series deliver exceptional precision with $\pm 0.1\%$ tolerance and low ± 25 ppm/ $^{\circ}\text{C}$ temperature coefficient. AEC-Q200 qualified with inherent anti-sulfuration properties and exceptional long-term stability, they are ideal for harsh automotive and industrial environments.

Susumu's metal alloy current sensing shunts are engineered with alloy technology and vacuum electron beam welding. The MSR series features resistance from 0.1 m Ω to

5 m Ω with proprietary "trimming-free" manufacturing that ensures uniform current distribution without hot spots, minimizing thermoelectric EMF effects. The MSRPM1216 delivers 7 W–10 W power handling with ± 100 ppm/ $^{\circ}\text{C}$ TCR in a 4-terminal configuration for precision applications, while the MSRPM2726 offers a superior TCR of $\pm 75/\pm 100$ ppm/ $^{\circ}\text{C}$. The MBRAS6918 series is specifically engineered for large-current sensing, capable of continuous operation at 500 A–700 A with 25 W power dissipation.

Its special heat treatment process achieves exceptional linearity with minimal resistance changes under varying currents, while withstanding pulse currents several times higher than rated values. With AEC-Q200 qualification, these shunts provide accurate high-frequency sensing across -55 $^{\circ}\text{C}$ to $+170$ $^{\circ}\text{C}$ for critical applications in EV battery management systems, motor control, etc.

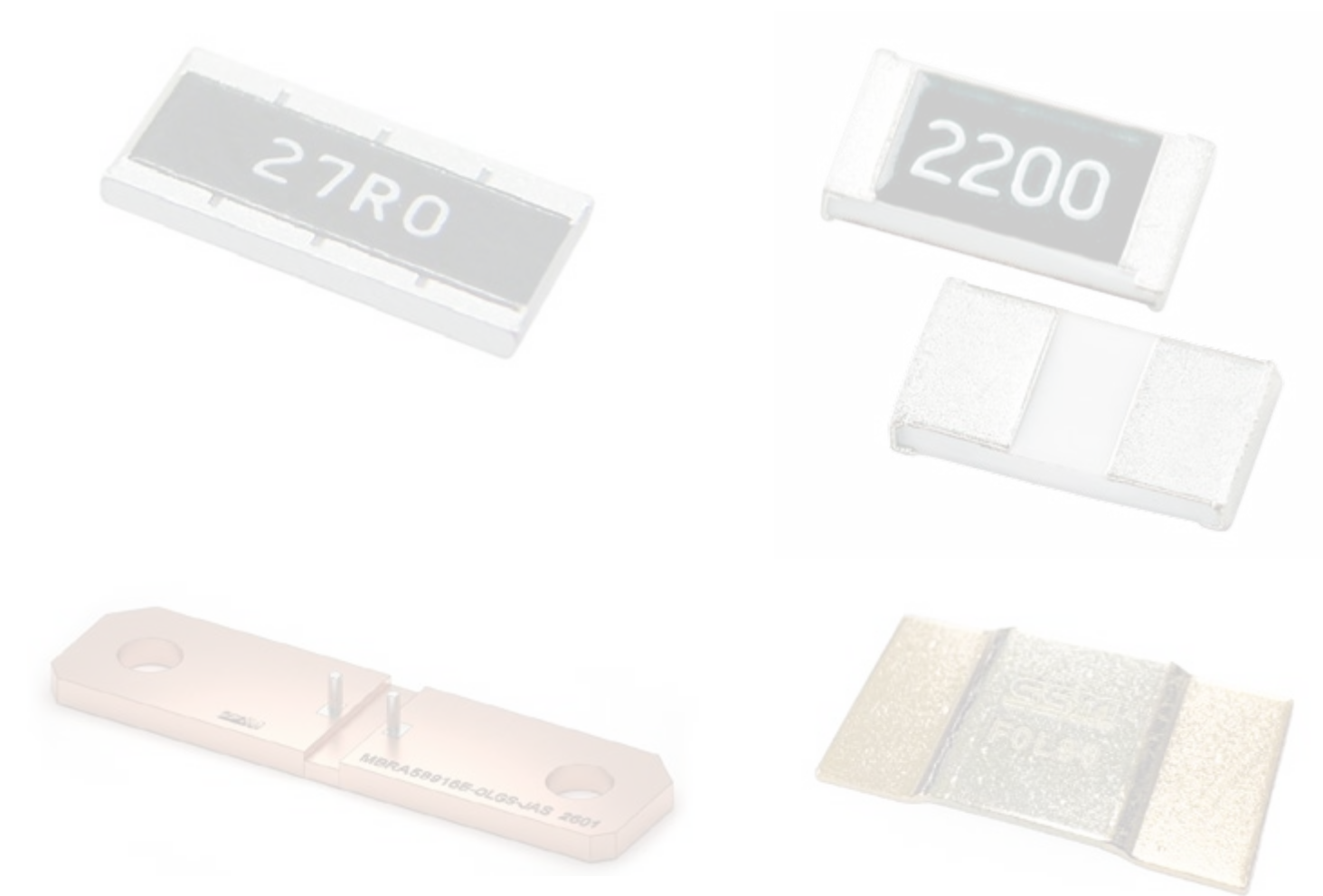

Series	Resistance	Power	Current	TCR
Orderable Part Numbers at arrow.com				
•	PRG3216P-1000-D-T5			
•	HRG3216P-1201-D-T1			
•	MSREM2512S-0L50-F4P0			
•	MSRPM5930R-0L80-F2P0			

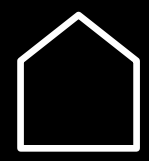

TDK's DC-Link Capacitors: ModCap family

ModCap – Modular DC-link capacitors for compact, high-power converters

ModCap is a modular, versatile DC-link capacitor concept that accelerates time-to-market for compact converters used in traction, renewable energy and industrial applications. Combined with the latest generation of power modules, ModCap enables compact, robust converter designs with high power density. Three product lines are available: ModCap MF for silicon IGBT modules and ModCap HF for silicon carbide (SiC) MOSFET modules, and ModCap UHP for higher temperatures up to +105 °C without derating.

ModCap HF is optimized for SiC-based converters and inverters. Its patented internal connection concept enables the capacitor to be mounted very close to the power modules, resulting in very low stray inductance of about 8 nH. This allows ModCap HF to efficiently absorb high-frequency harmonics and significantly reduce voltage overshoot at turn-off, so external snubber capacitors

are typically not required. The result is a more compact, lower-cost inverter design with high power density.

ModCap MF and HF use biaxially oriented polypropylene (BOPP) as the dielectric, enabling a continuous hotspot temperature rating of +90 °C and a lifetime of 200,000 hours at +80 °C hotspot temperature.

For more demanding applications, TDK has developed a next-generation dielectric to increase the allowable hotspot temperature to +105 °C without derating. This is implemented in the recently launched ModCap UHP.

To support system design, TDK provides simulation software that models the capacitor's thermal behavior based on input parameters and also calculates expected lifetime. This helps engineers optimize layout and cooling for reliable operation.

TDK is a global leader specializing in capacitors and a wide portfolio of electronic components, delivering innovative solutions to power diverse industries worldwide.



[More information on tdk.com](https://www.tdk.com)

[More information on arrow.com](https://www.arrow.com)

[Orderable Part Numbers at arrow.com](https://www.arrow.com)

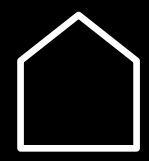

TDK's DC-Link Capacitors: ModCap family

ModCap – Modular DC-link capacitors for compact, high-power converters

ModCap is a modular, versatile DC-link capacitor concept that accelerates time-to-market for compact converters used in traction, renewable energy and industrial applications. Combined with the latest generation of power modules, ModCap enables compact, robust converter designs with high power density. Three product lines are available: ModCap MF for silicon IGBT modules and ModCap HF for silicon carbide (SiC) MOSFET modules, and ModCap UHP for higher temperatures up to +105 °C without derating.

ModCap HF is optimized for SiC-based converters and inverters. Its patented internal connection concept enables the capacitor to be mounted very close to the power modules, resulting in very low stray inductance of about 8 nH. This allows ModCap HF to efficiently absorb high-frequency harmonics and significantly reduce voltage overshoot at turn-off, so external snubber capacitors

are typically not required. The result is a more compact, lower-cost inverter design with high power density.

ModCap MF and HF use biaxially oriented polypropylene (BOPP) as the dielectric, enabling a continuous hotspot temperature rating of +90 °C and a lifetime of 200,000 hours at +80 °C hotspot temperature.

For more demanding applications, TDK has developed a next-generation dielectric to increase the allowable hotspot temperature to +105 °C without derating. This is implemented in the recently launched ModCap UHP.

To support system design, TDK provides simulation software that models the capacitor's thermal behavior based on input parameters and also calculates expected lifetime. This helps engineers optimize layout and cooling for reliable operation.

TDK is a global leader specializing in capacitors and a wide portfolio of electronic components, delivering innovative solutions to power diverse industries worldwide.

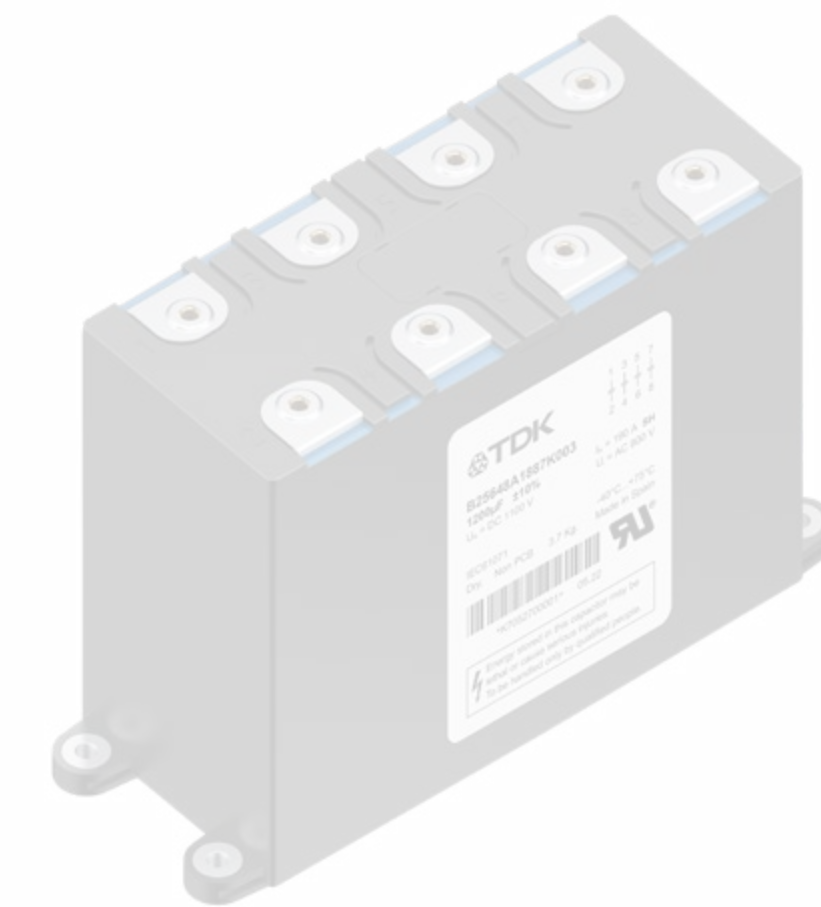

Orderable Part Series at arrow.com

- B25645A*
- B25647A*

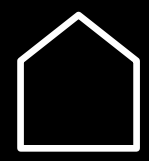

Power Resistors engineered for demanding Performance

Wide power ranges and robust construction

On Board Resistors: certified reliability with options offering AEC-Q200, IP ratings, UL compliance, tight tolerances, and broad resistance values

Off-Board: IP ratings, UL compliance, Vibration Resistant and broad resistance values

Introduction

TE Connectivity offers a broad and versatile portfolio of high-power resistors for both chassis-mount (up to 2.5 KW) and PCB-mount (up to 7 W) applications.

These resistors span a wide power range from lower-power designs up to multi-kilowatt solutions supporting demanding requirements such as inrush current limiting, semiconductor balancing, braking, load testing, and heavy industrial and traction uses.

The portfolio includes aluminium-housed and thick-film constructions that provide efficient thermal performance, stable electrical characteristics, and robust heat dissipation across a variety of industrial environments. TE also provides rugged economical options with strong

pulse-handling capability and vibration resistance, suitable for drives, inverters, and automation systems.

The PCB-mount resistor offering mirrors this breadth, with through-hole and surface-mount solutions designed for general-purpose electronics, industrial control boards, and power-supply applications. These components support reliable power dissipation across low to moderately high wattage levels while maintaining good surge performance and stable operation in compact layouts.

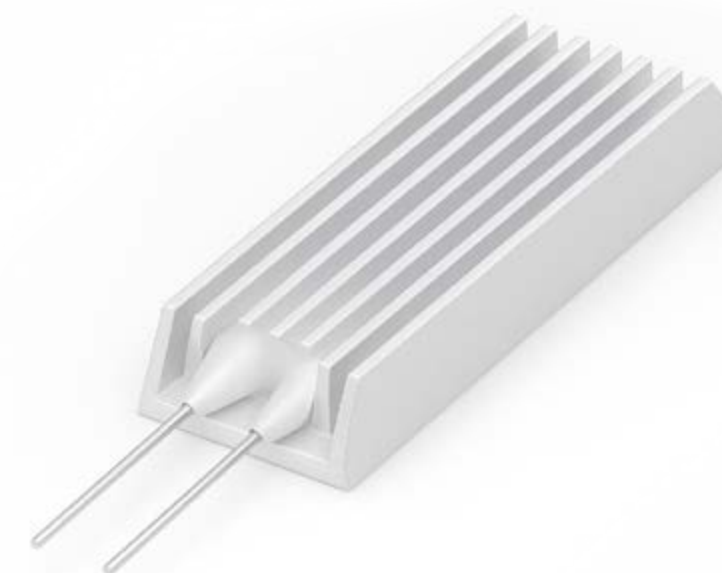
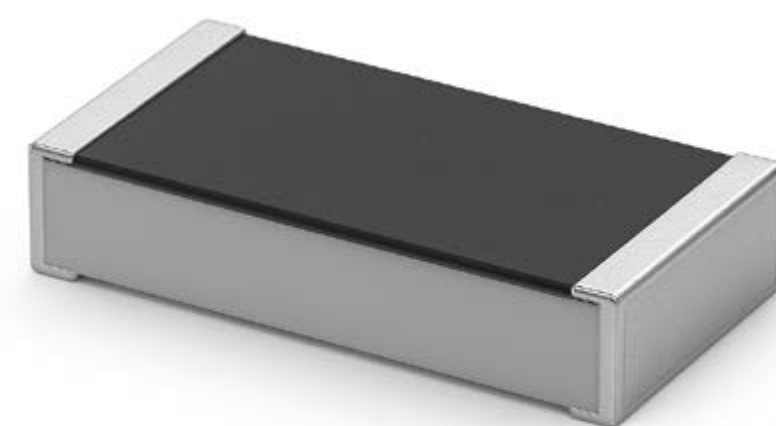
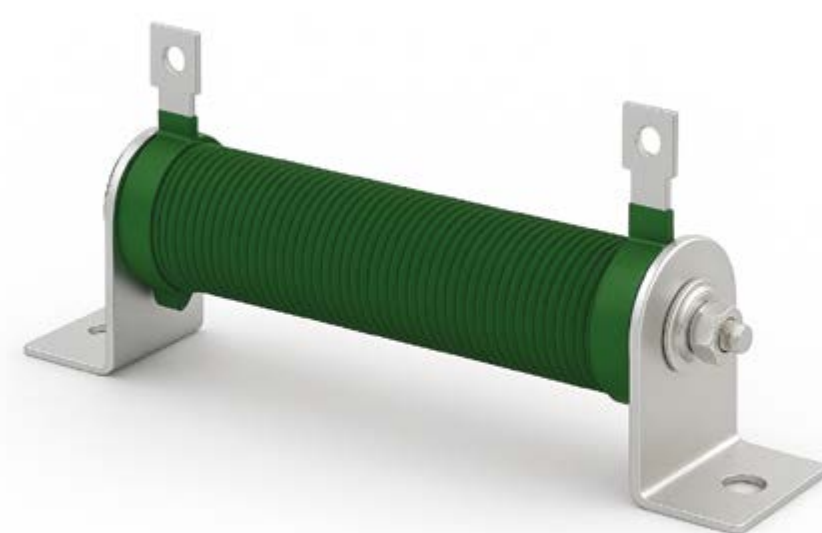

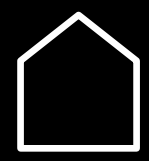

Power Resistors engineered for demanding Performance

Wide power ranges and robust construction

Key Benefits

- **Power Spectrum:**
From low-power PCB applications to multi-kilowatt chassis-mount designs.
- **High-Demand Usage:**
Including inrush limiting, braking, load testing, semiconductor balancing, and heavy industrial applications.
- **Strong Thermal Performance:**
Aluminium-housed and thick-film constructions provide efficient heat dissipation and stable operation.
- **Rugged and Reliable:**
Options with strong pulse handling and vibration resistance for drives, inverters, and automation systems.
- **Flexible PCB Solutions:**
Through-hole and SMD resistors support both robust and compact electronic designs.
- **Compliance Options:**
Select models offer AEC-Q200, IP ratings, and UL certifications.
- **Design Versatility:**
High power density, low-tolerance choices, wide ohmic ranges, and various package sizes.

Applications

More information on arrow.com

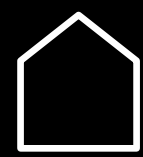

Power Resistors engineered for demanding Performance

Wide power ranges and robust construction

Key Benefits

- **Power Spectrum:**
From low-power PCB applications to multi-kilowatt chassis-mount designs.
- **High-Demand Usage:**
Including inrush limiting, braking, load testing, semiconductor balancing, and heavy industrial applications.
- **Strong Thermal Performance:**
Aluminium-housed and thick-film constructions provide efficient heat dissipation and stable operation.
- **Rugged and Reliable:**
Options with strong pulse handling and vibration resistance for drives, inverters, and automation systems.
- **Flexible PCB Solutions:**
Through-hole and SMD resistors support both robust and compact electronic designs.
- **Compliance Options:**
Select models offer AEC-Q200, IP ratings, and UL certifications.
- **Design Versatility:**
High power density, low-tolerance choices, wide ohmic ranges, and various package sizes.

Applications

✕

- On Board (PCB Mount)**
 - Industrial Controllers
 - EV charger
 - Industrial Machinery
 - Generators
 - Automotive
 - Power converters
- Off Board (Chassis Mounted)**
 - Elevators
 - Industrial Machinery
 - BESS
 - Cranes & forklifts
 - Welding machinery
 - Servo drives



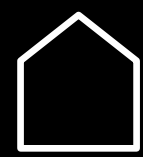

GTX Series EMI-RFI Filters

High-Performance EMI Suppression for Single-Phase & Three-Phase Equipment

By combining advanced core materials, selectable capacitance configurations, and highly efficient EMI topologies, the GTX Series provides robust, cost-effective filtering for next-generation electronic systems.

Key Benefits

- **Excellent Attenuation**
Nanocrystalline core material delivers high common mode and differential mode EMI suppression in a compact footprint.
- **Compact & Lightweight**
Plastic-case (single-phase) and metal-case (3-phase) designs with high mechanical density reduce system size and weight.
- **Flexible Y-Capacitor Options**
Off-the-shelf selectable Y-capacitor combinations support diverse equipment topologies and EMI standards compliance.
- **Reliable thermal performance**
Thanks to optimized internal structure and heat-dissipation mechanisms.

Product Types

- **Single-phase GTX filters (6-30 A)**
Compact plastic-case series with screw-terminal blocks, strong attenuation in a small size (75 × 44 × 25 mm, 121-133 g).



- **Three-phase GTX filters (30-60 A) & Three-phase + Neutral GTX filters (50-100 A)** Metal-case variants designed for industrial and inverter-driven equipment. High voltage tolerance (500 VAC / 500 VDC) and leakage-current options up to 92 mA support larger loads.



Applications

More information on arrow.com

Orderable Part Series at arrow.com

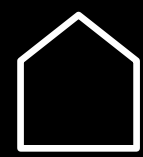

GTX Series EMI-RFI Filters

High-Performance EMI Suppression for Single-Phase & Three-Phase Equipment

By combining advanced core materials, selectable capacitance configurations, and highly efficient EMI topologies, the GTX Series provides robust, cost-effective filtering for next-generation electronic systems.

Key Benefits

- **Excellent Attenuation**
Nanocrystalline core material delivers high common mode and differential mode EMI suppression in a compact footprint.
- **Compact & Lightweight**
Plastic-case (single-phase) and metal-case (3-phase) designs with high mechanical density reduce system size and weight.
- **Flexible Y-Capacitor Options**
Off-the-shelf selectable Y-capacitor combinations support diverse equipment topologies and EMI standards compliance.
- **Reliable thermal performance**
Thanks to optimized internal structure and heat-dissipation mechanisms.

Product Types

- **Single-phase GTX filters (6-30 A)**
Compact plastic-case series with screw-terminal blocks, strong attenuation in a small size (75 × 44 × 25 mm, 121-133 g).



- **Three-phase GTX filters (30-60 A) & Three-phase + Neutral GTX filters (50-100 A)** Metal-case variants designed for industrial and inverter-driven equipment. High voltage tolerance (500 VAC / 500 VDC) and leakage-current options up to 92 mA support larger loads.

Applications

- Inverters & motor drives
- HVAC equipment
- Power storage system
- Robotics & automation
- Factory automation
- Power supplies & appliances
- Medical & lab devices
- EV charging station

[More information on arrow.com](#)

[Orderable Part Numbers at arrow.com](#)

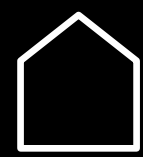

GTX Series EMI-RFI Filters

High-Performance EMI Suppression for Single-Phase & Three-Phase Equipment

By combining advanced core materials, selectable capacitance configurations, and highly efficient EMI topologies, the GTX Series provides robust, cost-effective filtering for next-generation electronic systems.

Key Benefits

- **Excellent Attenuation**
Nanocrystalline core material delivers high common mode and differential mode EMI suppression in a compact footprint.
- **Compact & Lightweight**
Plastic-case (single-phase) and metal-case (3-phase) designs with high mechanical density reduce system size and weight.
- **Flexible Y-Capacitor Options**
Off-the-shelf selectable Y-capacitor combinations support diverse equipment topologies and EMI standards compliance.
- **Reliable thermal performance**
Thanks to optimized internal structure and heat-dissipation mechanisms.

Product Types

- **Single-phase GTX filters (6-30 A)**
Compact plastic-case series with screw-terminal blocks, strong attenuation in a small size (75 × 44 × 25 mm, 121-133 g).

- **Three-phase GTX filters (30-60 A) & Three-phase + Neutral GTX filters (50-100 A)**
Metal-case variants designed for industrial and inverter-driven equipment. High voltage tolerance (500 VAC / 500 VDC) and leakage-current options up to 92 mA support larger loads.

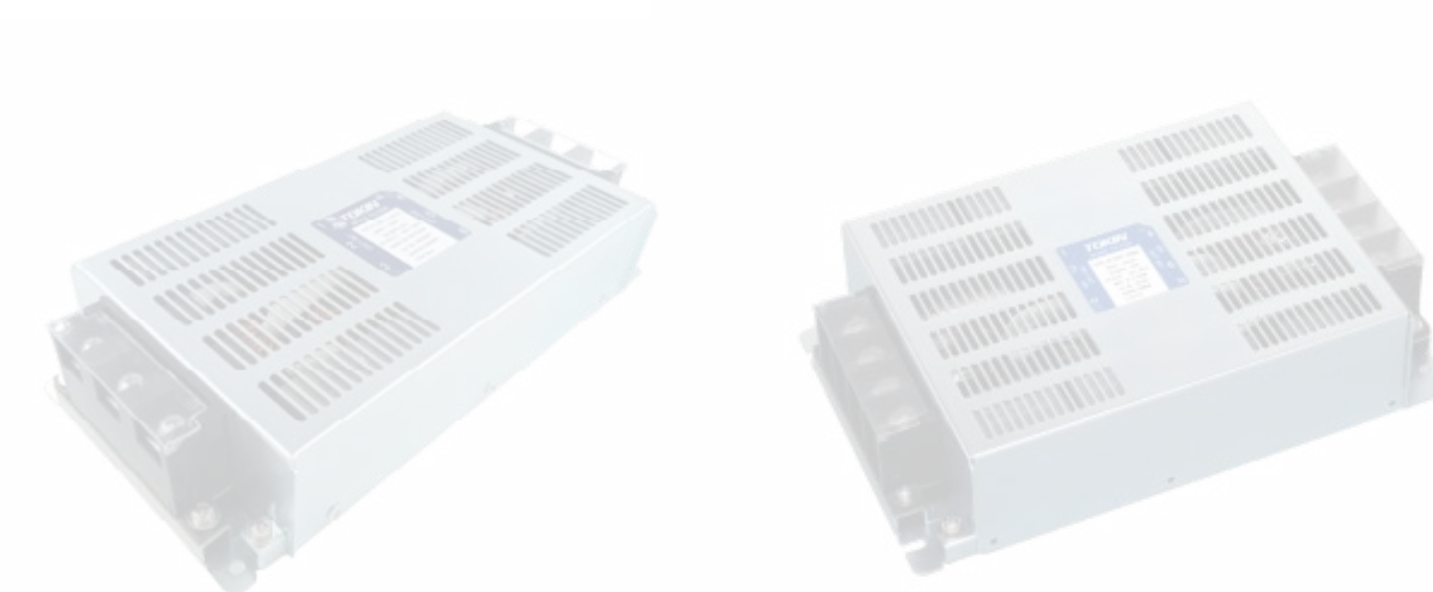

Applications ✕

Orderable Part Series at arrow.com

- [GTX-Series](#)

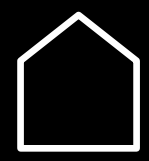

Power Up Your Design with Yageo / KEMET Power Box DC Link Film Capacitors

KEMET delivers high-reliability DC-Link film capacitors for high-power applications, enabling compact designs, high ripple current capability, and robust operation in harsh and high-temperature environments.

KEMET Power Box DC-Link

Modern power electronics demand higher power density, increased reliability, and extended lifetime under extreme operating conditions. KEMET Power Box DC-Link capacitors address these challenges with a comprehensive portfolio covering miniaturized designs, harsh-environment robustness, and high-temperature capability, supporting both automotive and non-automotive platforms.

Advantages

- High ripple current and high dV/dt capability
- High voltage capability
- Optimized for high power density and compact system designs

- Proven reliability under high humidity and thermal stress
- AEC-Q200 qualified for automotive and industrial deployment
- Self-healing metallized polypropylene technology

Features

- Capacitance range up to 210 μ F
- Voltage ratings up to 1800 VDC
- Operating temperature up to 135 °C (series dependent)
- THB Grade IIIB (85 °C / 85 % RH / 1,000 h at VNDC)
- Low ESL and low losses for demanding DC-Link stages
- Low profile solutions available

Product Portfolio

C4AQ-M – Miniaturized DC-Link High capacitance density enabling smaller system size or increased energy storage.

C4AU – DC-Link for Harsh Environments Designed for high humidity and harsh

operating conditions without lifetime compromise.

C4AK – High-Temperature DC-Link First-to-market solution enabling continuous operation up to 125 °C and extended lifetime up to 135 °C.

Selection Guide					
Maximum Temperature	Life at Max. Temp. Δ C/C, \leq 5%	THB Robustness Δ C/C, \leq 5%	DC-Link Series	Key Features	
125 °C	200 h	60 °C / 95 % RH 1,000 h at Vr	C4AQ	High Ripple Current, Low ESL, Low Profiles	
		85 °C / 85 % RH 1,000 h at Vr	C4AQ-M Miniaturized	Miniaturization, Higher dv/dt, Low ESL, Low Profiles	
	2,000 h 3,000 h	85 °C / 85 % RH 1,000 h at Vr	C4AU	Higher Ripple, Higher dv/dt, Low ESL, Low Profile, Miniaturization, Extended Life at THB test	
		85 °C / 85 % RH 1,000 h at 0.95 * Vr	R75H R76H	Highest Ripple Current and dv/dt, Low Profile, 0.1 nF to 33 μ F, up to 2,000 V	
135 °C	1,000 h (4,000 h at 125 °C)	85 °C / 85 % RH 1,000 h at Vr	C4AQ-P	Higher Ripple, Higher dv/dt, Low ESL, Low Profile, Miniaturization, Extended Life at 125 °C	
		85 °C / 85 % RH 1,000 h at Vr	C4AK	Higher Ripple, Higher dv/dt, Low ESL, Low Profile, Extended Life at 135 °C, THB test	

Applications

More information on arrow.com

Orderable Part Numbers at arrow.com

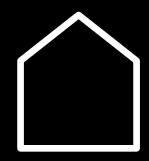

Power Up Your Design with Yageo / KEMET Power Box DC Link Film Capacitors

KEMET delivers high-reliability DC-Link film capacitors for high-power applications, enabling compact designs, high ripple

- Proven reliability under high humidity and thermal stress
- AEC-Q200 qualified for automotive

operating conditions without lifetime compromise.



Selection Guide

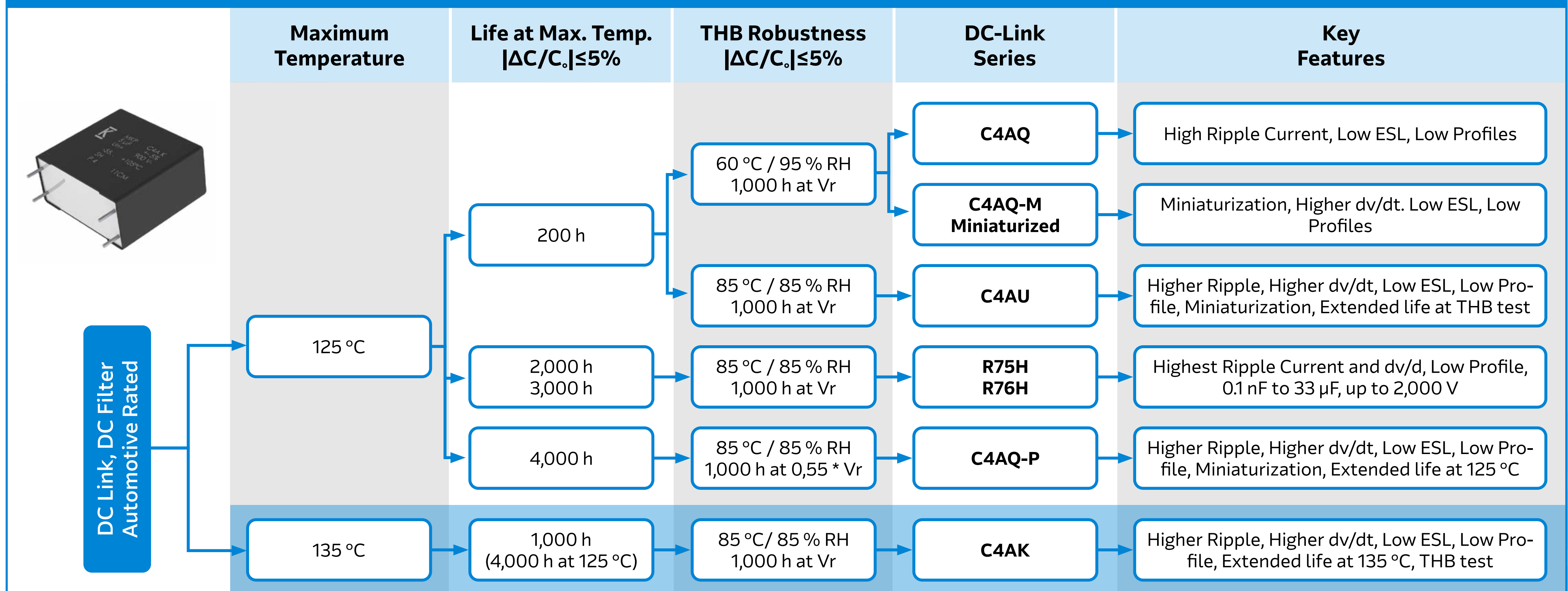

Optimized for high power density and compact system designs

Designed for high humidity and harsh

Orderable Part Numbers at arrow.com

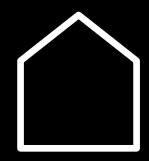

Power Up Your Design with Yageo / KEMET Power Box DC Link Film Capacitors

KEMET delivers high-reliability DC-Link film capacitors for high-power applications, enabling compact designs, high ripple current capability, and robust operation in harsh and high-temperature environments.

KEMET Power Box DC-Link

Modern power electronics demand higher power density, increased reliability, and extended lifetime under extreme operating conditions. KEMET Power Box DC-Link capacitors address these challenges with a comprehensive portfolio covering miniaturized designs, harsh-environment robustness, and high-temperature capability, supporting both automotive and non-automotive platforms.

Advantages

- High ripple current and high dV/dt capability
- High voltage capability
- Optimized for high power density and compact system designs

- Proven reliability under high humidity and thermal stress
- AEC-Q200 qualified for automotive and industrial deployment
- Self-healing metallized polypropylene technology

Features

- Capacitance range up to 210 μ F
- Voltage ratings up to 1800 VDC
- Operating temperature up to 135 °C (series dependent)
- THB Grade IIIB (85 °C / 85 % RH / 1,000 h at VNDC)
- Low ESL and low losses for demanding DC-Link stages
- Low profile solutions available

Product Portfolio

C4AQ-M – Miniaturized DC-Link High capacitance density enabling smaller system size or increased energy storage.

C4AU – DC-Link for Harsh Environments Designed for high humidity and harsh

operating conditions without lifetime compromise.



Applications

- Automotive On-Board Chargers (OBC)
- DC/DC converters and traction inverters
- Solar inverters and energy storage systems
- EV charging infrastructure
- Motor drives and industrial inverters
- High-temperature and harsh-environment power electronics
- AI (HVDC infrastructure, PSU, thermal management etc.)

[More information on arrow.com](#)

[Orderable Part Numbers at arrow.com](#)

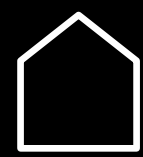

Power Up Your Design with Yageo / KEMET Power Box DC Link Film Capacitors

KEMET delivers high-reliability DC-Link film capacitors for high-power applications, enabling compact designs, high ripple current capability, and robust operation in harsh and high-temperature environments.

KEMET Power Box DC-Link

Modern power electronics demand higher power density, increased reliability, and extended lifetime under extreme operating conditions. KEMET Power Box DC-Link capacitors address these challenges with a comprehensive portfolio covering miniaturized designs, harsh-environment robustness, and high-temperature capability, supporting both automotive and non-automotive platforms.

Advantages

- High ripple current and high dV/dt capability
- High voltage capability
- Optimized for high power density and compact system designs

- Proven reliability under high humidity and thermal stress
- AEC-Q200 qualified for automotive and industrial deployment
- Self-healing metallized polypropylene technology

Features

- Capacitance range up to 210 μ F
- Voltage ratings up to 1800 VDC
- Operating temperature up to 135 °C (series dependent)
- THB Grade IIIB (85 °C / 85 % RH / 1,000 h at VNDC)
- Low ESL and low losses for demanding DC-Link stages
- Low profile solutions available

Product Portfolio

C4AQ-M – Miniaturized DC-Link
High capacitance density enabling smaller system size or increased energy storage.

C4AU – DC-Link for Harsh Environments
Designed for high humidity and harsh

operating conditions without lifetime compromise.

C4AK – High-Temperature DC-Link
First-to-market solution enabling continuous operation up to 125 °C and extended lifetime up to 135 °C.

Selection Guide					
DC-Link DC Film Automotive Rated	Maximum Temperature	Life at Max. Temp. [AC/C, \leq 5%]	THB Robustness [AC/C, \leq 5%]	DC-Link Series	Key Features
	125 °C	200 h	60 °C / 95 % RH 1,000 h at Vr	C4AQ	High Ripple Current, Low ESL, Low Profiles
		2,000 h	85 °C / 85 % RH 1,000 h at Vr	C4AQ-M Miniaturized	Miniaturization, Higher dv/dt, Low ESL, Low Profiles
	135 °C	3,000 h	85 °C / 85 % RH 1,000 h at Vr	C4AU	Higher Ripple, Higher dv/dt, Low ESL, Low Profile, Miniaturization, Extended life at THB test
		4,000 h	85 °C / 85 % RH 1,000 h at 0.55 * Vr	R7SH R7BH	Highest Ripple Current and dv/dt, Low Profile, 0.1 nF to 33 μ F, up to 2,000 V
	1,000 h (4,000 h at 125 °C)	85 °C / 85 % RH 1,000 h at Vr	C4AQ-P	Higher Ripple, Higher dv/dt, Low ESL, Low Profile, Miniaturization, Extended life at 125 °C	
		85 °C / 85 % RH 1,000 h at Vr	C4AK	Higher Ripple, Higher dv/dt, Low ESL, Low Profile, Extended life at 135 °C, THB test	

Applications

Orderable Part Series at arrow.com

- [C4A* Series](#)

