



**NLT Technologies**

# **TFT COLOR LCD MODULE**

## **NL8048AC19-13BD**

**18cm (7.0 Type)**

**WVGA**

**LVDS interface (1port)**

### **DATA SHEET**

**DOD-PP-2128 (1st edition)**



**This DATA SHEET is updated document from  
PRELIMINARY DATA SHEET DOD-PP-1813(2).**

**All information is subject to change without notice.  
Please confirm the sales representative before starting  
to design your system.**

## INTRODUCTION

The Copyright to this document belongs to NLT Technologies, Ltd. (hereinafter called "NLT"). No part of this document will be used, reproduced or copied without prior written consent of NLT.

NLT does and will not assume any liability for infringement of patents, copyrights or other intellectual property rights of any third party arising out of or in connection with application of the products described herein except for that directly attributable to mechanisms and workmanship thereof. No license, express or implied, is granted under any patent, copyright or other intellectual property right of NLT.

Some electronic products would fail or malfunction at a certain rate. In spite of every effort to enhance reliability of products by NLT, the possibility of failures and malfunction might not be avoided entirely. To prevent the risks of damage to death, human bodily injury or other property arising out thereof or in connection therewith, each customer is required to take sufficient measures in its safety designs and plans including, but not limited to, redundant system, fire-containment and anti-failure.

The products are classified into three grades: "**Standard**", "**Special**", and "**Specific**".

Each quality grade is designed for applications described below. Any customer who intends to use a product for application other than that of Standard is required to contact an NLT sales representative in advance.

**The Standard:** Applications as any failure, malfunction or error of the products are free from any damage to death, human bodily injury or other property (Products Safety Issue) and not related the safety of the public (Social Issues), like general electric devices.

Examples: Office equipment, audio and visual equipment, communication equipment, test and measurement equipment, personal electronic equipment, home electronic appliances, car navigation system (with no vehicle control functions), seat entertainment monitor for vehicles and airplanes, fish finder (except marine radar integrated type), PDA, etc.

**The Special:** Applications as any failure, malfunction or error of the products might directly cause any damage to death, human bodily injury or other property (Products Safety Issue) and the safety of the public (Social Issues) and required high level reliability by conventional wisdom.

Examples: Vehicle/train/ship control system, traffic signals system, traffic information control system, air traffic control system, surgery/operation equipment monitor, disaster/crime prevention system, etc.

**The Specific:** Applications as any failure, malfunction or error of the products might severe cause any damage to death, human bodily injury or other property (Products Safety Issue) and the safety of the public (Social Issues) and developed, designed and manufactured in accordance with the standards or quality assurance program designated by the customer who requires extremely high level reliability and quality.

Examples: Aerospace system (except seat entertainment monitor), nuclear control system, life support system, etc.

The quality grade of this product is the "**Standard**" unless otherwise specified in this document.

## CONTENTS

<b>INTRODUCTION .....</b>	<b>2</b>
<b>1. OUTLINE.....</b>	<b>4</b>
1.1 STRUCTURE AND PRINCIPLE .....	4
1.2 APPLICATION .....	4
1.3 FEATURES .....	4
<b>2. GENERAL SPECIFICATIONS.....</b>	<b>5</b>
<b>3. BLOCK DIAGRAM.....</b>	<b>6</b>
<b>4. DETAILED SPECIFICATIONS.....</b>	<b>7</b>
4.1 MECHANICAL SPECIFICATIONS .....	7
4.2 ABSOLUTE MAXIMUM RATINGS.....	7
4.3 ELECTRICAL CHARACTERISTICS.....	8
4.3.1 LCD panel signal processing board .....	8
4.3.2 LED driver .....	8
4.3.3 Power supply voltage ripple.....	9
4.3.4 Fuse.....	9
4.4 TOUCH PANEL SPECIFICATION .....	10
4.5 POWER SUPPLY VOLTAGE SEQUENCE .....	11
4.5.1 LCD panel signal processing board .....	11
4.5.2 LED driver .....	11
4.6 CONNECTIONS AND FUNCTIONS FOR INTERFACE PINS .....	12
4.6.1 LCD panel signal processing board .....	12
4.6.2 LED driver .....	13
4.6.3 Touch panel.....	13
4.6.4 Positions of plug and socket .....	13
4.6.5 Connection between receiver and transmitter for LVDS .....	14
4.6.6 Input data mapping .....	15
4.7 DISPLAY COLORS AND INPUT DATA SIGNALS.....	15
4.8 DISPLAY POSITIONS .....	16
4.9 SCANNING DIRECTIONS .....	16
4.10 TOUCH PANEL POSITIONS .....	17
4.11 INPUT SIGNAL TIMINGS .....	18
4.11.1 Outline of input signal timings .....	18
4.11.2 Timing characteristics .....	19
4.11.3 Input signal timing chart .....	20
4.12 OPTICS.....	21
4.12.1 Optical characteristics .....	21
4.12.2 Definition of contrast ratio.....	22
4.12.3 Definition of luminance uniformity .....	22
4.12.4 Definition of response times .....	22
4.12.5 Definition of viewing angles.....	22
<b>5. ESTIMATED LUMINANCE LIFETIME.....</b>	<b>23</b>
<b>6. RELIABILITY TESTS .....</b>	<b>24</b>
<b>7. PRECAUTIONS .....</b>	<b>25</b>
7.1 MEANING OF CAUTION SIGNS .....	25
7.2 CAUTIONS .....	25
7.3 ATTENTIONS.....	25
7.3.1 Handling of the product .....	25
7.3.2 Environment.....	26
7.3.3 Characteristics.....	26
7.3.4 Others.....	27
<b>8. OUTLINE DRAWINGS.....</b>	<b>28</b>
8.1 FRONT VIEW .....	28
8.2 REAR VIEW .....	29

## 1. OUTLINE

### 1.1 STRUCTURE AND PRINCIPLE

Color LCD module NL8048AC19-13BD is composed of the amorphous silicon thin film transistor liquid crystal display (a-Si TFT LCD) panel structure with driver LSIs for driving the TFT (Thin Film Transistor) array, touch panel (T/P) and a backlight.

The a-Si TFT LCD panel structure is injected liquid crystal material into a narrow gap between the TFT array glass substrate and a color-filter glass substrate.

Color (Red, Green, Blue) data signals from a host system (e.g. signal generator, etc.) are modulated into best form for active matrix system by a signal processing board, and sent to the driver LSIs which drive the individual TFT arrays.

The TFT array as an electro-optical switch regulates the amount of transmitted light from the backlight assembly, when it is controlled by data signals. Color images are created by regulating the amount of transmitted light through the TFT array of red, green and blue dots.

### 1.2 APPLICATION

- For industrial use

### 1.3 FEATURES

- Projected capacitive touch panel (PCAP T/P) attached
- Touch panel having cover glass
- High luminance
- High contrast
- Wide viewing angle
- LVDS interface
- Reversible-scan direction
- LED backlight built in LED driver
- Acquisition product for UL60950-1/CSA C22.2 No.60950-1-03 (File number: E170632)
- Compliant with the European RoHS directive (2011/65/EU)



2. GENERAL SPECIFICATIONS

<i>Display area</i>	152.4 (H) × 91.44 (V) mm	
<i>Diagonal size of display</i>	18cm (7.0 inches)	
<i>Drive system</i>	a-Si TFT active matrix	
<i>Display color</i>	262,144 colors	
<i>Pixel</i>	800 (H) × 480 (V) pixels	
<i>Pixel arrangement</i>	BGR (Blue dot, Green dot, Red dot) vertical stripe	☆
<i>Dot pitch</i>	0.0635 (H) × 0.1905 (V) mm	
<i>Pixel pitch</i>	0.1905 (H) × 0.1905 (V) mm	
<i>Module size (Including Touch Panel)</i>	170.0 (H) × 111.0 (V) × 10.6 (D) mm (typ.)	☆
<i>Weight</i>	245g (typ.)	☆
<i>Contrast ratio</i>	800:1 (typ.)	☆
<i>Viewing angle</i>	At the contrast ratio ≥10:1 <ul style="list-style-type: none"> <li>• Horizontal: Right side 80° (typ.), Left side 80° (typ.)</li> <li>• Vertical: Up side 80° (typ.), Down side 80° (typ.)</li> </ul>	
<i>Designed viewing direction</i>	At DPS= Low or Open: Normal scan <ul style="list-style-type: none"> <li>• Viewing direction without image reversal: Up side (12 o'clock)</li> <li>• Viewing direction with contrast peak: Down side (6 o'clock)</li> <li>• Viewing angle with optimum grayscale (γ ≈ 2.2): Normal axis (perpendicular)</li> </ul>	
<i>Color gamut</i>	At LCD panel center 60 % (typ.) [against NTSC color space]	
<i>Response time</i>	Ton+Toff (10%←→90%) 8ms (typ.)	☆
<i>Luminance</i>	At the maximum luminance control 430cd/m <sup>2</sup> (typ.)	☆
<i>Touch panel type</i>	Projected capacitive <div style="border-left: 1px solid black; border-right: 1px solid black; border-bottom: 1px solid black; padding: 5px; margin-left: 20px;">                     Recommended T/P controller board (Option)                      • T/P controller board: PTPW04/05                 </div>	
<i>Touch panel surface</i>	Antiglare + AFP(Anti-finger print)	
<i>Touch panel pencil-hardness</i>	2H(min.) [by JIS K5600]	☆
<i>Touch panel cover glass</i>	• Thickness: 0.7mm glass	
<i>Touch panel bonding method</i>	Perimeter-bonding (with air gap)	
<i>Signal system</i>	LVDS interface (1port) (Receiver: SN65LVDS86AQDGGR, Texas Instruments Inc. or equivalent) 6-bit digital signals for data of RGB colors, Dot clock (CLK), Data enable (DE)	
<i>Power supply voltage</i>	LCD panel signal processing board: 3.3V LED driver: 12.0V	
<i>Backlight</i>	LED backlight built in LED driver	
<i>Power consumption</i>	At the maximum luminance control, Checkered flag pattern Driving with the recommended T/P controller board, The number of touch= 10 3.3W (typ.)	☆

3. BLOCK DIAGRAM

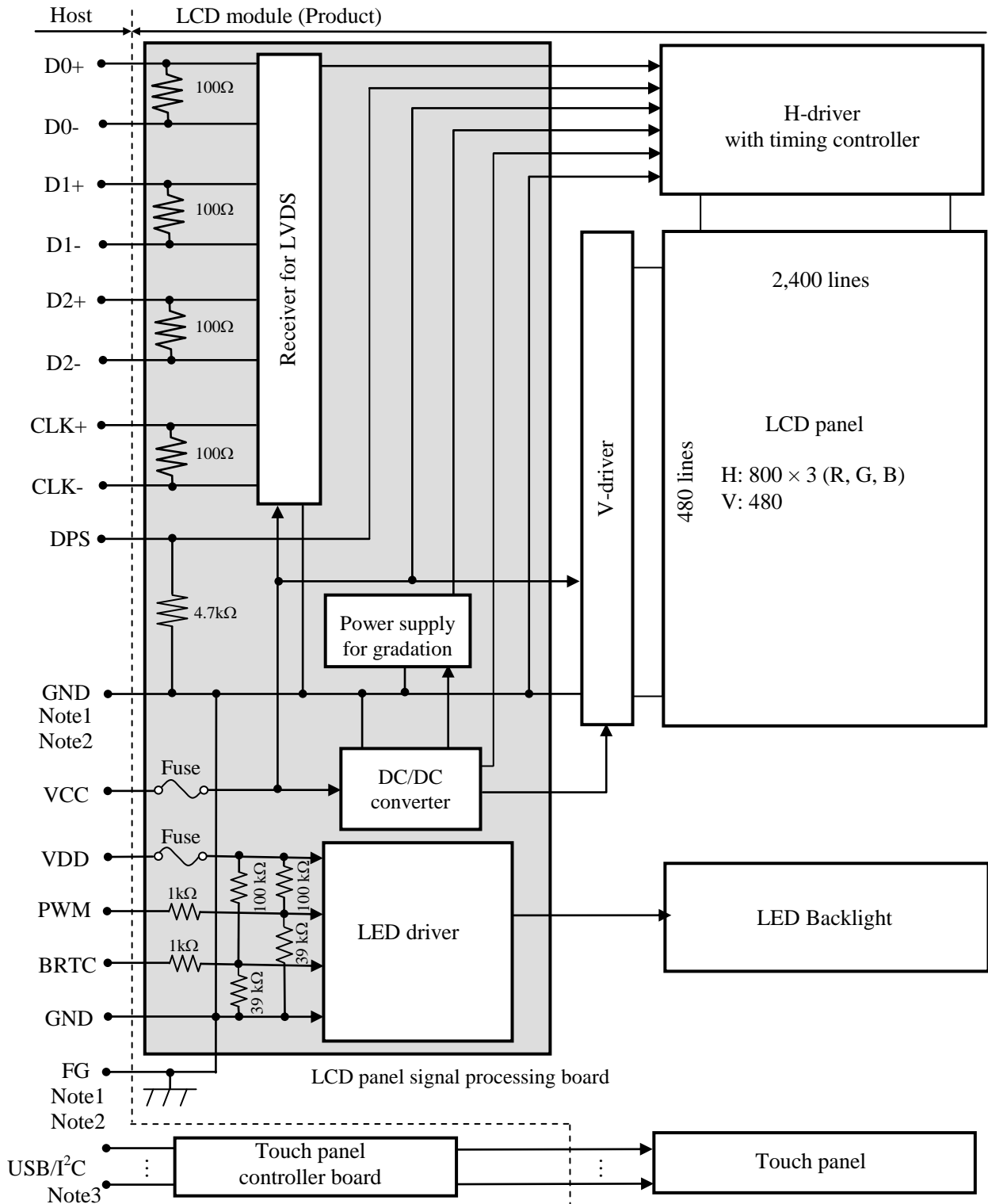

Note1: Relation between GND (Signal ground and LED driver ground) and FG (Frame ground) in the LCD module is as follows.

GND- FG	Connected
---------	-----------

Note2: GND and FG must be connected to customer equipment's ground, and it is recommended that these grounds to be connected together in customer equipment.

Note3: Refer to the specifications of T/P controller board.

4. DETAILED SPECIFICATIONS

4.1 MECHANICAL SPECIFICATIONS

Parameter	Specification	Unit
Module size (Including Touch Panel)	170.0 ± 0.5 (W) × 111.0 ± 0.5 (H) × 10.6 ± 0.6 (D) Note1	mm
Display area	152.4 (H) × 91.44 (V) Note1	mm
Weight	245 (typ.), 270 (max.)	g

☆

☆

Note1: See "8. OUTLINE DRAWINGS".

4.2 ABSOLUTE MAXIMUM RATINGS

(Note1)

Parameter	Symbol	Rating	Unit	Remarks		
Power supply voltage	LCD panel signal processing board	VCC	-0.3 to +3.96	V	Ta = 25°C	
	LED driver	VDD	-0.3 to +15.0			
Input voltage for signals	Display signals Note2	VD	-0.3 to VCC+0.3	V		
	Function signals Note3	VF				
	Function signal for LED driver	PWM				-0.3 to +5.5
BRTC		-0.3 to +VDD+0.1	V			
Storage temperature	Tst	-40 to +80	°C	-		
Operating temperature	Front surface	TopF	-30 to +80	°C		Note4
	Rear surface	TopR	-30 to +80	°C		Note5
Relative humidity Note6	RH	≤ 95	%	Ta ≤ 40°C		
		≤ 85	%	40°C < Ta ≤ 50°C		
		≤ 55	%	50°C < Ta ≤ 60°C		
		≤ 36	%	60°C < Ta ≤ 70°C		
		≤ 24	%	70°C < Ta ≤ 80°C		
Absolute humidity Note6	AH	≤ 70 Note7	g/m <sup>3</sup>	Ta = 80°C		

☆

☆

Note1: Regarding the driving of T/P, refer to the specifications of T/P controller board.

Note2: D0+/-, D1+/-, D2+/- and CLK+/-

Note3: DPS

Note4: Measured at T/P surface (including self-heat)

Note5: Measured at LCD module's rear shield surface (including self-heat)

Note6: No condensation.

Note7: Water amount at Ta= 80°C and RH= 24%

4.3 ELECTRICAL CHARACTERISTICS

4.3.1 LCD panel signal processing board

(Ta= 25°C)

Parameter	Symbol	min.	typ.	max.	Unit	Remarks	
Power supply voltage	VCC	3.0	3.3	3.6	V	-	
Power supply current	ICC	-	190 Note1	290 Note2	mA	at VCC= 3.3V	
Permissible ripple voltage	VRPC	-	-	100	mVp-p	for VCC	
Differential input threshold voltage	High	VTH	-	-	+100	mV	at VCM= 1.2 V Note3
	Low	VTL	-100	-	-	mV	
Terminating resistance	RT	-	100	-	Ω	-	
Input voltage for DPS signals	High	VFH	0.7VCC	-	VCC	V	CMOS level
	Low	VFL	0	-	0.3VCC	V	
Input current for DPS signal	High	IFH	-	-	+800	μA	-
	Low	IFL	-800	-	-	μA	

Note1: Checkered flag pattern [by EIAJ ED-2522]

Note2: Pattern for maximum current

Note3: Common mode voltage for LVDS receiver

4.3.2 LED driver

(Ta= 25°C)

Parameter	Symbol	min.	typ.	max.	Unit	Remarks	
Power supply voltage	VDD	10.8	12.0	13.2	V	Note1	
Power supply current	IDD	-	200	220 Note3	mA	Note4	
Permissible ripple voltage	VRPD	-	-	200	mVp-p	for VDD	
Input voltage for PWM signal	High	VDFH1	2.0	-	5.3	V	-
	Low	VDFL1	-	-	0.4	V	
Input voltage for BRTC signal	High	VDFH2	2.0	-	VDD	V	-
	Low	VDFL2	-	-	0.4	V	
PWM frequency	f <sub>PWM</sub>	100	-	10k	Hz	Note5, Note6	
PWM duty ratio	DR <sub>PWM</sub>	0.1	-	100	%	Note7	
PWM pulse width	t <sub>PWH</sub>	0.1	-	-	μs		

Note1: When designing of the power supply, take the measures for the prevention of surge voltage.

Note2: The power supply lines (VDD and GND) may have ripple voltage during luminance control of LED. There is the possibility that the ripple voltage produces acoustic noise and signal wave noise in audio circuit and so on. Put a capacitor between the power supply lines (VDD and GND) to reduce the noise if necessary.

Note3: This value excludes peak current such as overshoot current.

Note4: At the maximum luminance control.

Note5: A recommended  $f_{PWM}$  value is as follows.

$$f_{PWM} = \frac{2n - 1}{4} \times fv$$

(n = integer, fv = frame frequency of LCD module)

Note6: Depending on the frequency used, some noise may appear on the screen, please conduct a thorough evaluation.

Note7: While the BRTC signal is high, do not set the tPWH (PWM pulse width) is less than 0.1μs. It may cause abnormal working of the backlight. In this case, turn the backlight off and then on again by BRTC signal.

#### 4.3.3 Power supply voltage ripple

This product works, even if the ripple voltage levels are over the permissible values as the following table, but there might be noise on the display image.

Power supply voltage		Ripple voltage (Measure at input terminal of power supply)	Note1	Unit
VCC	3.3V	≤ 100		mVp-p
VDD	12.0V	≤ 200		mVp-p

Note1: The permissible ripple voltage includes spike noise.

#### 4.3.4 Fuse

Parameter	Fuse		Rating	Fusing current	Remarks
	Type	Supplier			
VCC	FCC16152AB	KAMAYA ELECTRIC CO.,LTD	1.5A	3.0A	Note1
			36V		
VDD	FCC16152AB	KAMAYA ELECTRIC CO.,LTD	1.5A	3.0A	
			36V		

Note1: The power supply's rated current must be more than the fusing current. If it is less than the fusing current, the fuse may not blow in a short time, and then nasty smell, smoke and so on may occur.

4.4 TOUCH PANEL SPECIFICATION

(Ta= 25°C, Note1)

Parameter	Symbol	min.	typ.	max.	Unit	Remarks	
Accuracy	Center	Acrc	-	-	1.5	mm	Note2
	Boarder	Acrb	-	-	2.5	mm	
Number of touch	NUM	1	-	16	Point	-	
Minimum distance for dual touch	Horizontal	Tdist H	12.0			mm	Note3
	Vertical	Tdist V	12.0				
Scan speed	Active	Sspd A	-	100	-	Hz	-
	Idle	Sspd I	-	30	-	Hz	-
Resolution	Horizontal	-	-	-	4,096	-	Note4
	Vertical	-	-	-	4,096	-	
Response area	Horizontal	-	-	154.4	-	mm	Note5
	Vertical	-	-	93.44	-		

Note1: If a customer uses a recommended T/P controller board, specifications of the T/P controller board are given priority over the specifications in this table.

Note2: Definition of accuracy

Accuracy shows a difference between an ideal position and an actual position.

Acrc: Accuracy at center area

Acrb: Accuracy at boarder area

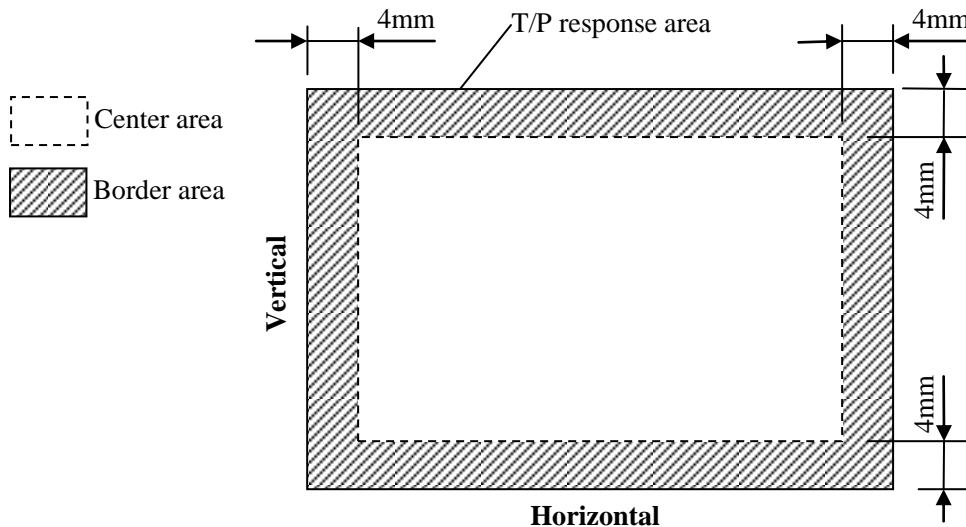

Input method is  $\phi 8\text{mm}$  conductive stylus.

Note3: Minimum distance for dual touch

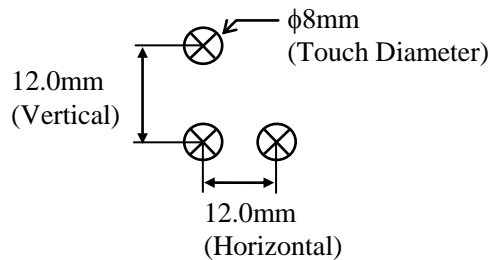

Note4: When using the recommended T/P controller board

Note5: The center point of the T/P response area and the center point of the display area are arranged at the same position.

4.5 POWER SUPPLY VOLTAGE SEQUENCE

4.5.1 LCD panel signal processing board

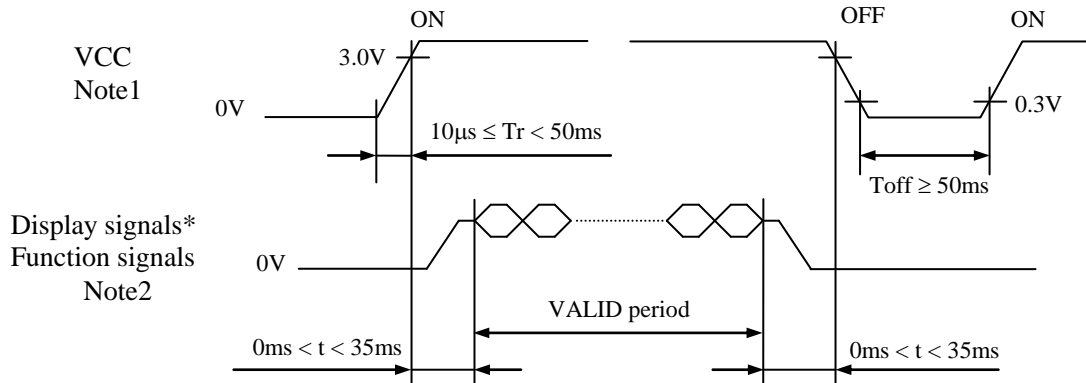

\* These signals should be measured at the terminal of 100Ω resistance.

Note1: If there is a voltage variation (voltage drop) at the rising edge of VCC below 3.0V, there is a possibility that a product does not work due to a protection circuit.

Note2: Display signals (D0+/-, D1+/-, D2+/- and CLK+/-) and function signals (DPS) must be set to Low or High-impedance, except the VALID period (See above sequence diagram), in order to avoid the circuitry damage.

If some of display and function signals of this product are cut while this product is working, even if the signal input to it once again, it might not work normally. If a customer stops the display and function signals, VCC also must be shut down.

4.5.2 LED driver

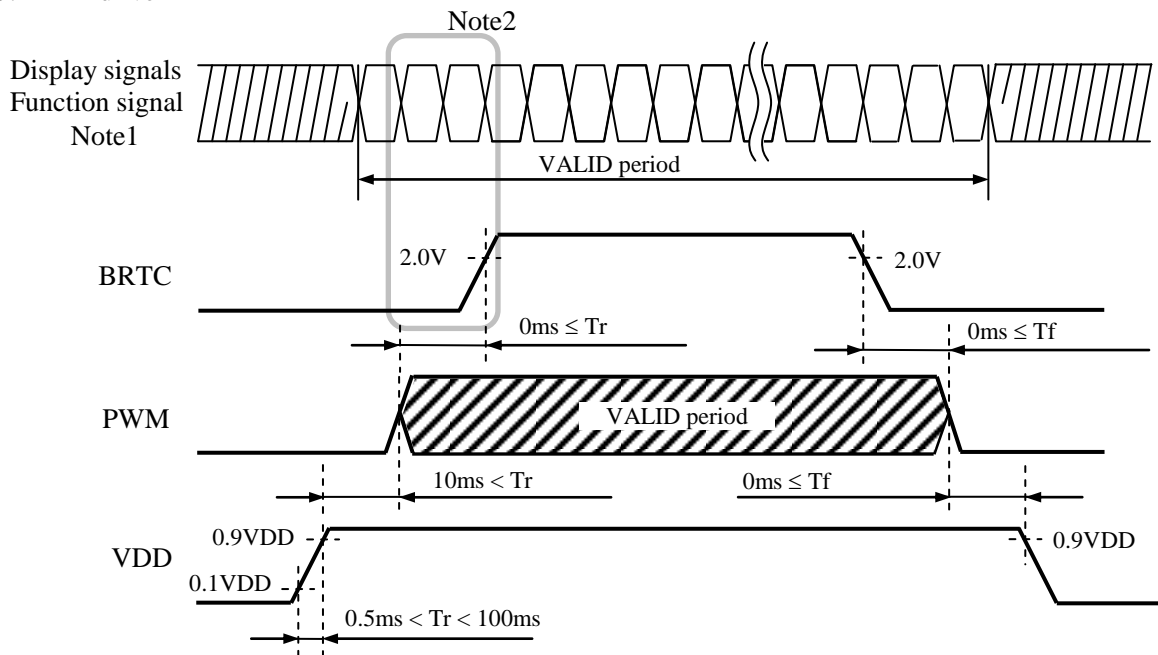

Note1: These are the display and function signals for LCD panel signal processing board.

Note2: The backlight should be turned on within the valid period of display and function signals, in order to avoid unstable data display.

4.6 CONNECTIONS AND FUNCTIONS FOR INTERFACE PINS

4.6.1 LCD panel signal processing board

CN1 socket (LCD module side): FI-SE20P-HFE (Japan Aviation Electronics Industry Limited (JAE))  
 Adaptable plug: FI-S20S (Japan Aviation Electronics Industry Limited (JAE))

Pin No.	Symbol	Signal	Remarks
1	GND	Ground	Note4
2	GND		
3	DPS	Selection of scan direction	High : Reverse scan Low or Open : Normal scan Note2
4	N.C.	-	Keep this pin Open.
5	GND	Ground	Note4
6	CLK+	Pixel clock	Note3
7	CLK-		
8	GND	Ground	Note4
9	D2+	Pixel data (B2-B5,DE)	Note1, Note3
10	D2-		
11	GND	Ground	Note4
12	D1+	Pixel data (G1-G5,B0-B1)	Note1, Note3
13	D1-		
14	GND	Ground	Note4
15	D0+	Pixel data (R0-R5,G0)	Note1, Note3
16	D0-		
17	GND	Ground	Note4
18	GND		
19	VCC	Power supply	Note4
20	VCC		

Note1: See "4.7 DISPLAY COLORS AND INPUT DATA SIGNALS".

Note2: See "4.9 SCANNING DIRECTIONS".

Note3: Twist pair wires with 100Ω (Characteristic impedance) should be used between LCD panel signal processing board and LVDS transmitter.

Note4: All GND and VCC terminals should be used without any non-connected lines.

4.6.2 LED driver

CN2 socket (LCD module side): FI-S6P-HFE (Japan Aviation Electronics Industry Limited (JAE))  
 Adaptable plug: FI-S6S (Japan Aviation Electronics Industry Limited (JAE))

Pin No.	Symbol	Function	Remarks
1	VDD	Power supply	Note1
2	VDD	Power supply	
3	GND	Ground	
4	GND	Ground	
5	BRTC	Backlight ON/OFF control	High or Open: Backlight ON Low: Backlight OFF
6	PWM	Luminance control terminal by PWM Dimming	High or Open: 100% (Max. Luminance)

Note1: All GND and VDD terminals must be connected to appropriate terminals.

4.6.3 Touch panel

Connect CN3 and CN4 to the sockets of the T/P controller board.

CN3: FPC (40 pins)  
 Adaptable socket: FH28-40S-0.5SH(05) (Hirose Electric Co., Ltd.(HRS))

CN4: FPC (60 pins)  
 Adaptable socket: FH28-60S-0.5SH(05) (Hirose Electric Co., Ltd.(HRS))

4.6.4 Positions of plug and socket

Rear side

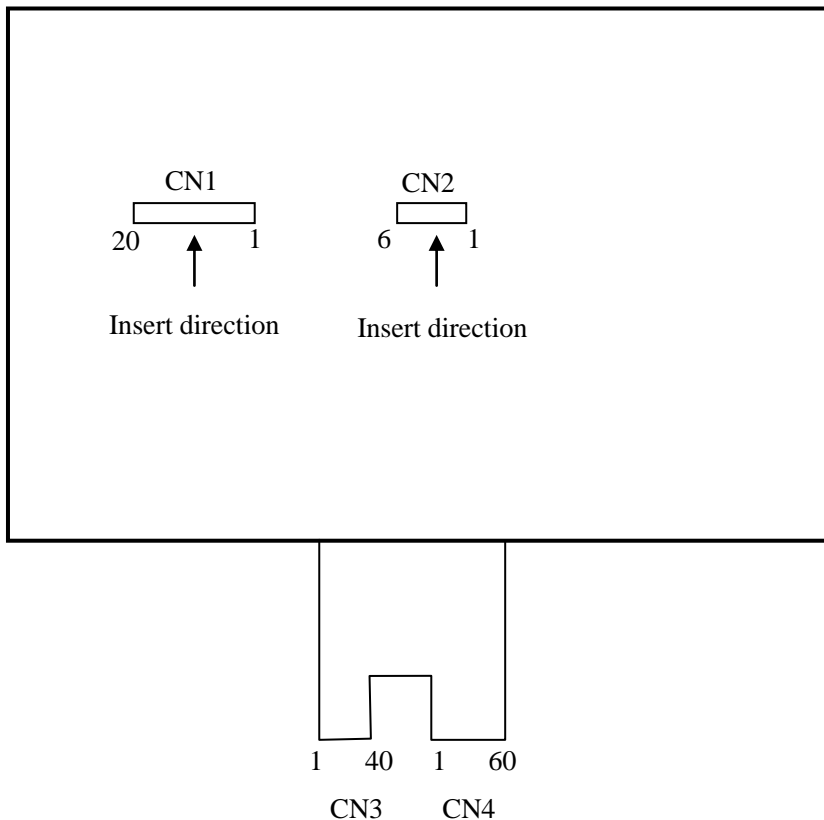

4.6.5 Connection between receiver and transmitter for LVDS

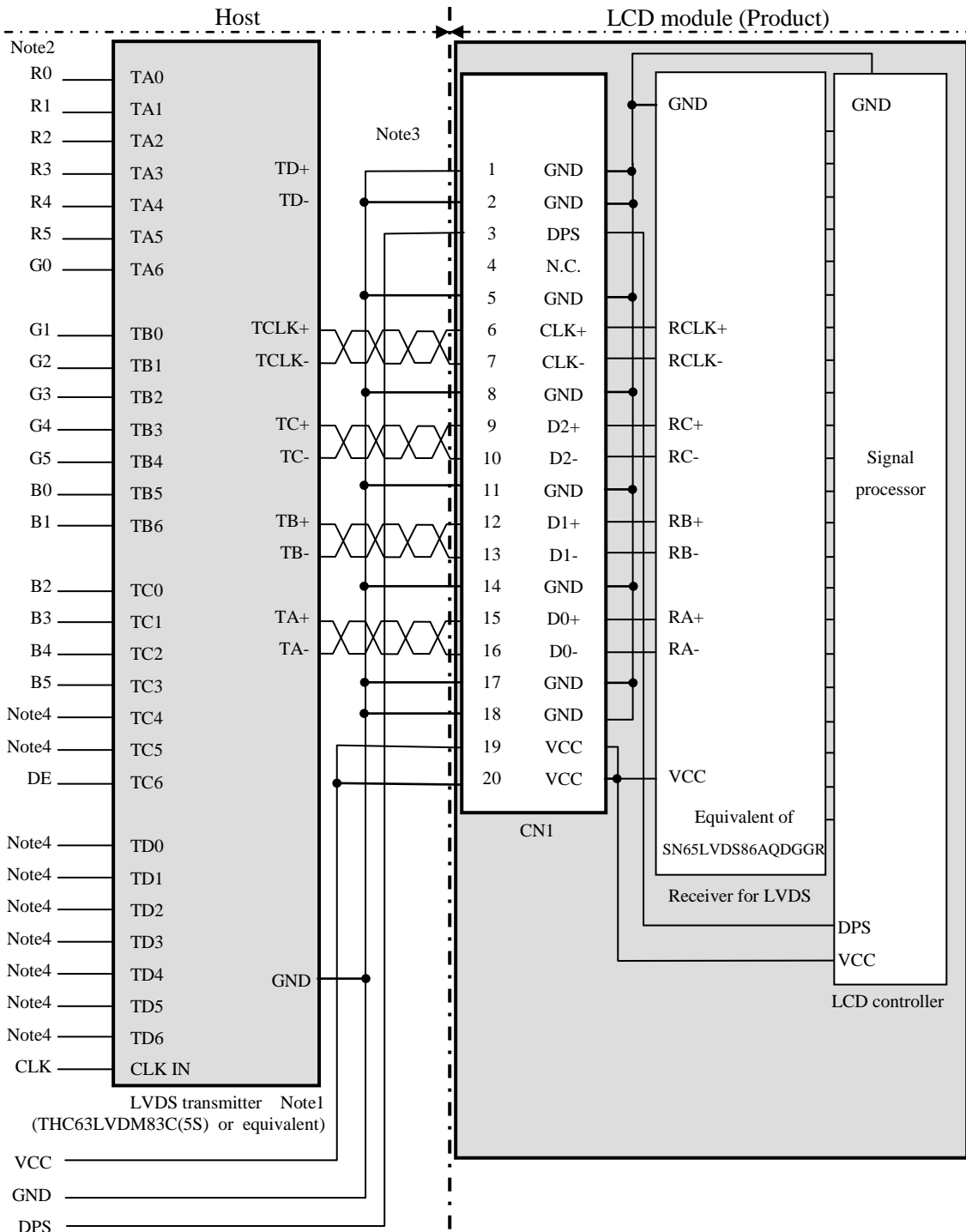

Note1: Recommended transmitter: THC63LVDM83C(5S) (THine Electronics Inc.) or equivalent

Note2: LSB (Least Significant Bit) – R0, G0, B0 MSB (Most Significant Bit) – R5, G5, B5

Note3: Twist pair wires with 100Ω (Characteristic impedance) should be used between LCD panel signal processing board and LVDS transmitter.

Note4: Input signals to TC4, TC5 and TD0-6 are not used inside the product, but do not keep them open to avoid noise problem.



4.6.6 Input data mapping

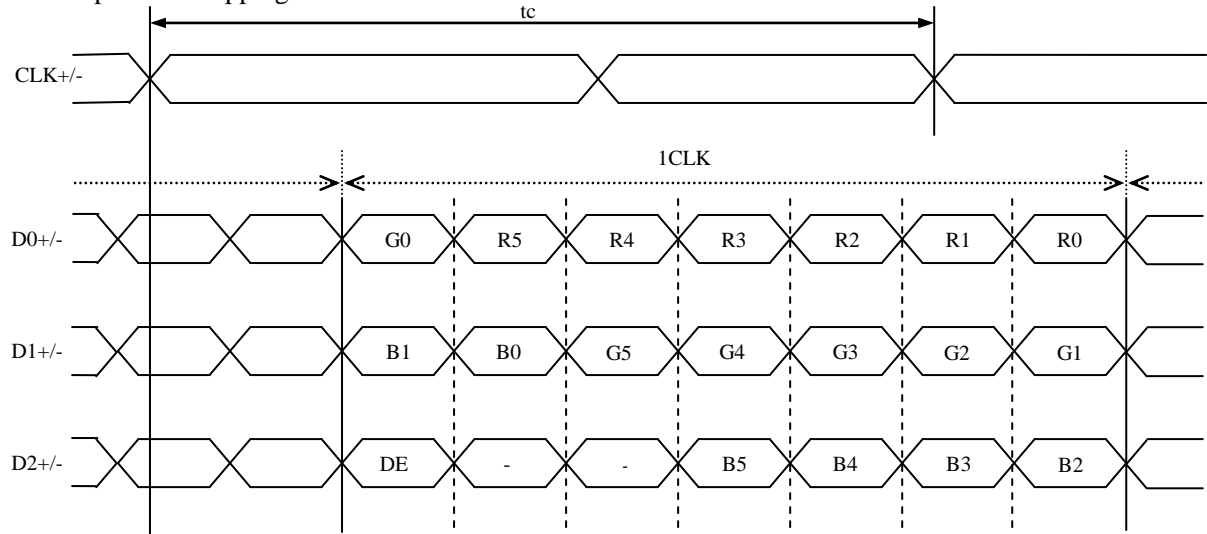

4.7 DISPLAY COLORS AND INPUT DATA SIGNALS

This product can display 262,144 colors with 64 gray scales. Also the relation between display colors and input data signals is as follows.

Display colors		Data signal (0: Low level, 1: High level)																	
		R5	R4	R3	R2	R1	R0	G5	G4	G3	G2	G1	G0	B5	B4	B3	B2	B1	B0
Basic colors	Black	0	0	0	0	0	0	0	0	0	0	0	0	0	0	0	0	0	0
	Blue	0	0	0	0	0	0	0	0	0	0	0	0	1	1	1	1	1	1
	Red	1	1	1	1	1	1	0	0	0	0	0	0	0	0	0	0	0	0
	Magenta	1	1	1	1	1	1	0	0	0	0	0	0	1	1	1	1	1	1
	Green	0	0	0	0	0	0	1	1	1	1	1	1	0	0	0	0	0	0
	Cyan	0	0	0	0	0	0	1	1	1	1	1	1	1	1	1	1	1	1
	Yellow	1	1	1	1	1	1	1	1	1	1	1	1	0	0	0	0	0	0
	White	1	1	1	1	1	1	1	1	1	1	1	1	1	1	1	1	1	1
Red gray scale	Black	0	0	0	0	0	0	0	0	0	0	0	0	0	0	0	0	0	0
	dark	0	0	0	0	0	1	0	0	0	0	0	0	0	0	0	0	0	0
	↑				⋮														
	↓				⋮														
	bright	1	1	1	1	0	1	0	0	0	0	0	0	0	0	0	0	0	0
Red	1	1	1	1	1	0	0	0	0	0	0	0	0	0	0	0	0	0	
Green gray scale	Black	0	0	0	0	0	0	0	0	0	0	0	0	0	0	0	0	0	0
	dark	0	0	0	0	0	0	0	0	0	0	1	0	0	0	0	0	0	0
	↑				⋮														
	↓				⋮														
	bright	0	0	0	0	0	0	1	1	1	1	0	1	0	0	0	0	0	0
Green	0	0	0	0	0	0	1	1	1	1	1	0	0	0	0	0	0	0	
Blue gray scale	Black	0	0	0	0	0	0	0	0	0	0	0	0	0	0	0	0	0	0
	dark	0	0	0	0	0	0	0	0	0	0	0	0	0	0	0	0	1	0
	↑				⋮														
	↓				⋮														
	bright	0	0	0	0	0	0	0	0	0	0	0	0	1	1	1	1	0	1
Blue	0	0	0	0	0	0	0	0	0	0	0	0	1	1	1	1	1	0	
Blue	0	0	0	0	0	0	0	0	0	0	0	0	1	1	1	1	1	1	

4.8 DISPLAY POSITIONS

The following table is the coordinates per pixel (See "4.9 SCANNING DIRECTIONS".).

C (0, 0)						
B	G	R				
C( 0, 0)	C( 1, 0)	...	C( X, 0)	...	C(798, 0)	C(799, 0)
C( 0, 1)	C( 1, 1)	...	C( X, 1)	...	C(798, 1)	C(799, 1)
.	.	.	.	.	.	.
.	.	...	.	...	.	...
.	.	.	.	.	.	.
C( 0, Y)	C( 1, Y)	...	C( X, Y)	...	C(798, Y)	C(799, Y)
.	.	.	.	.	.	.
.	.	...	.	...	.	.
.	.	.	.	.	.	.
C( 0, 478)	C( 1, 478)	...	C( X, 478)	...	C(798, 478)	C(799, 478)
C( 0, 479)	C( 1, 479)	...	C( X, 479)	...	C(798, 479)	C(799, 479)



4.9 SCANNING DIRECTIONS

The following figures are seen from a front view.

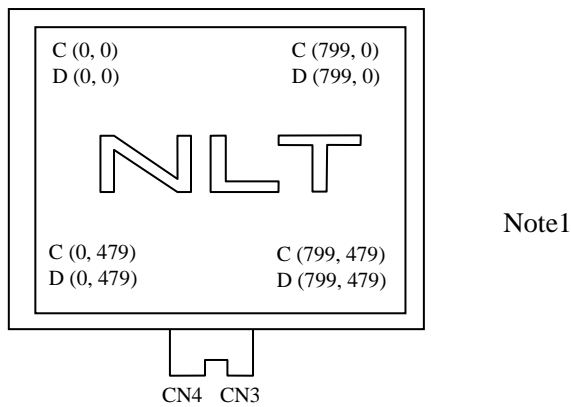

Figure1. Normal scan (DPS: Low or Open)

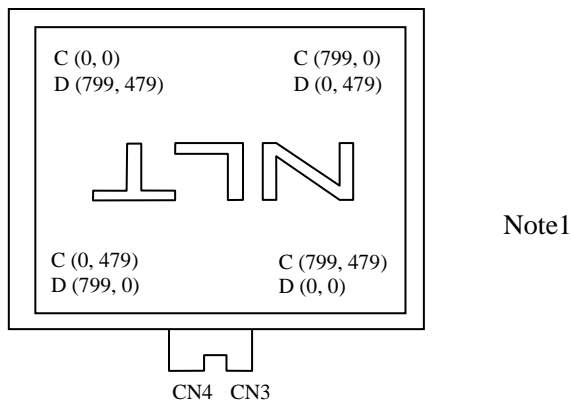

Figure2. Reverse scan (DPS: High)

Note1: Meaning of C (X, Y) and D (X, Y)

C (X, Y):The coordinates of the display position (See "4.8 DISPLAY POSITIONS".)

D (X, Y):The data number of input signal for LCD panel signal processing board

4.10 TOUCH PANEL POSITIONS

The following figure is the coordinates of the T/P from the front view.

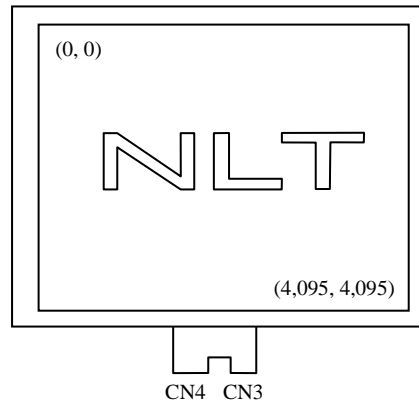

4.11 INPUT SIGNAL TIMINGS

4.11.1 Outline of input signal timings

- Horizontal signal

Note1

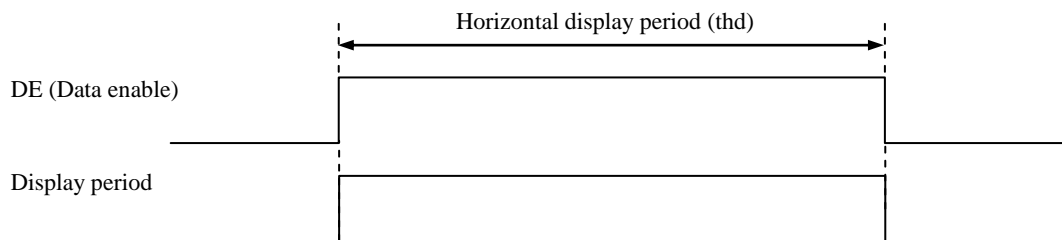

- Vertical signal

Note1

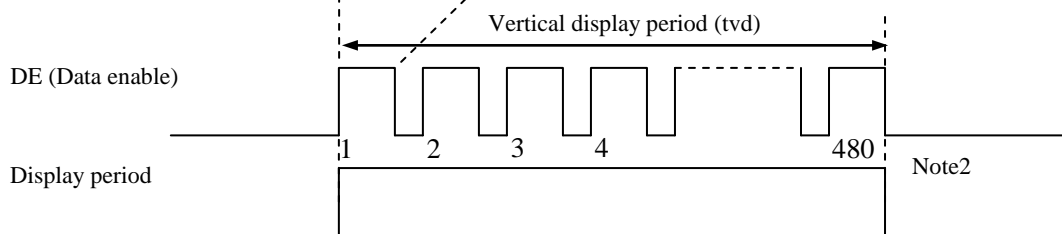

Note1: This diagram indicates virtual signal for set up to timing.

Note2: See "4.11.3 Input signal timing chart" for the pulse number.

4.11.2 Timing characteristics

(Note1, Note2, Note3)

Parameter		Symbol	min.	typ.	max.	Unit	Remarks	
CLK	Frequency	1/tc	28.0	32.256	36.0	MHz	31.002ns (typ.)	
	Duty ratio	-	-			-	-	
	Rise time, Fall time	-				ns		
DATA	CLK-DATA	Setup time	-			ns	-	
		Hold time				ns		
	Rise time, Fall time	-				ns		
DE	Horizontal	Cycle	th	28.44	31.746	36.57	μs	31.5 kHz (typ.)
				-	1,024	-	CLK	
		Display period	thd	800			CLK	-
	Vertical (One frame)	Cycle	tv	14.931	16.667	19.19	ms	60.0 Hz (typ.)
				-	525	-	H	
		Display period	tvd	480			H	-
	CLK-DE	Setup time	-	-			ns	-
Hold time		-	ns					
	Rise time, Fall time	-				ns		

Note1: Definition of parameters is as follows.

tc= 1CLK, th= 1H

Note2: See the data sheet of LVDS transmitter.

Note3: Vertical cycle (tv) should be specified in integral multiple of Horizontal cycle (th).

4.11.3 Input signal timing chart

Horizontal timing

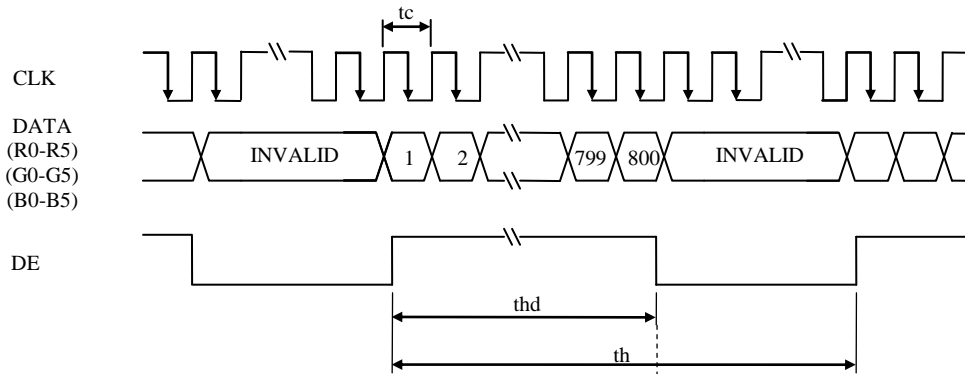

Vertical timing

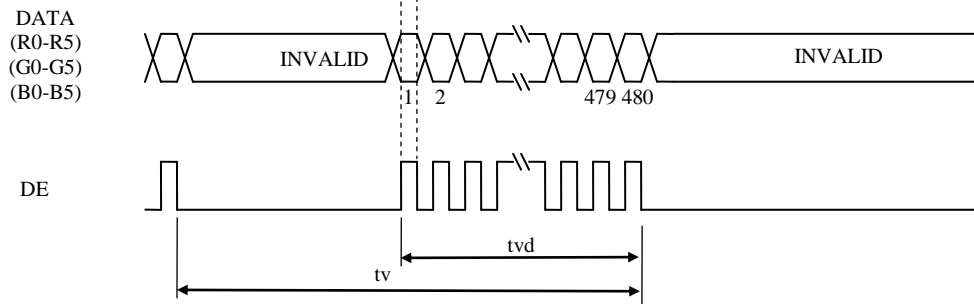

4.12 OPTICS

4.12.1 Optical characteristics

(Note1, Note2)

Parameter	Condition	Symbol	min.	typ.	max.	Unit	Measuring instrument	Remarks	
Luminance	White at center $\theta R=0^\circ, \theta L=0^\circ, \theta U=0^\circ, \theta D=0^\circ$	L	250	430	-	cd/m <sup>2</sup>	BM-5A	- ☆	
Contrast ratio	White/Black at center $\theta R=0^\circ, \theta L=0^\circ, \theta U=0^\circ, \theta D=0^\circ$	CR	500	800	-	-	BM-5A	Note3 ☆	
Luminance uniformity	White $\theta R=0^\circ, \theta L=0^\circ, \theta U=0^\circ, \theta D=0^\circ$	LU	-	1.25	1.4	-	BM-5A	Note4 ☆	
Chromaticity	White	x coordinate	Wx	0.263	0.313	0.363	-	SR-3	Note5 ☆
		y coordinate	Wy	0.279	0.329	0.379	-		
	Red	x coordinate	Rx	-	0.613	-	-		
		y coordinate	Ry	-	0.347	-	-		
	Green	x coordinate	Gx	-	0.316	-	-		
		y coordinate	Gy	-	0.609	-	-		
Blue	x coordinate	Bx	-	0.151	-	-			
	y coordinate	By	-	0.087	-	-			
Color gamut	$\theta R=0^\circ, \theta L=0^\circ, \theta U=0^\circ, \theta D=0^\circ$ at center, against NTSC color space	C	55	60	-	%			
Response time	White to Black	Ton	-	3	5	ms	BM-5A	Note6 ☆	
	Black to White	Toff	-	5	8	ms	-10000	Note7	
Viewing angle	Right	$\theta U=0^\circ, \theta D=0^\circ, CR \geq 10$	$\theta R$	70	80	-	EZ Contrast	Note8 ☆	
	Left	$\theta U=0^\circ, \theta D=0^\circ, CR \geq 10$	$\theta L$	70	80	-			
	Up	$\theta R=0^\circ, \theta L=0^\circ, CR \geq 10$	$\theta U$	70	80	-			
	Down	$\theta R=0^\circ, \theta L=0^\circ, CR \geq 10$	$\theta D$	70	80	-			

Note1: These are initial characteristics.

Note2: Measurement conditions are as follows.

Ta = 25°C, VCC = 3.3V, VDD = 12.0V, PWM duty ratio: 100%,  
 Display mode: WVGA, Horizontal cycle = 1/31.5kHz, Vertical cycle = 1/60.0Hz,  
 DPS= Low or Open: Normal scan

Optical characteristics are measured at luminance saturation 20minutes after the product works, in the dark room. Also measurement methods are as follows.

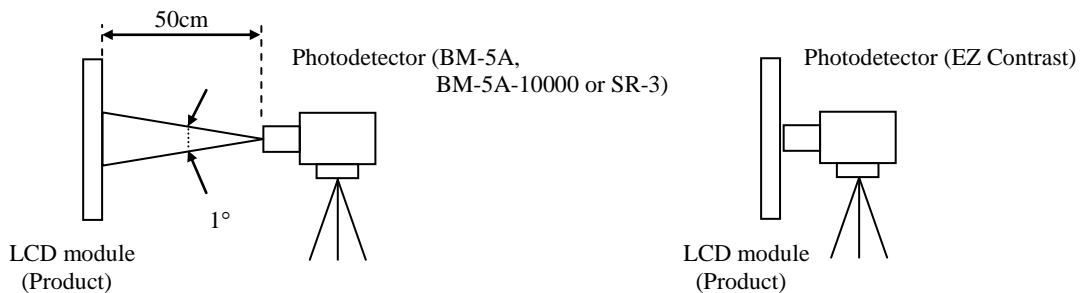

Note3: See "4.12.2 Definition of contrast ratio".

Note4: See "4.12.3 Definition of luminance uniformity".

Note5: These coordinates are found on CIE 1931 chromaticity diagram.

Note6: Product surface temperature: TopF= 34°C

Note7: See "4.12.4 Definition of response times".

Note8: See "4.12.5 Definition of viewing angles".

4.12.2 Definition of contrast ratio

The contrast ratio is calculated by using the following formula.

$$\text{Contrast ratio (CR)} = \frac{\text{Luminance of white screen}}{\text{Luminance of black screen}}$$

4.12.3 Definition of luminance uniformity

The luminance uniformity is calculated by using following formula.

$$\text{Luminance uniformity (LU)} = \frac{\text{Maximum luminance from ① to ⑤}}{\text{Minimum luminance from ① to ⑤}}$$

The luminance is measured at near the 5 points shown below.

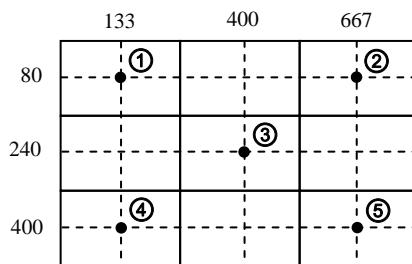

4.12.4 Definition of response times

Response time is measured at the time when the luminance changes from "white" to "black", or "black" to "white" on the same screen point, by photo-detector. Ton is the time when the luminance changes from 90% down to 10%. Also Toff is the time when the luminance changes from 10% up to 90% (See the following diagram.).

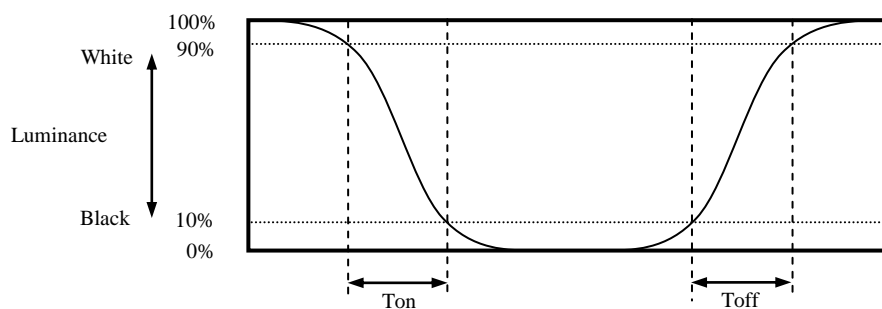

4.12.5 Definition of viewing angles

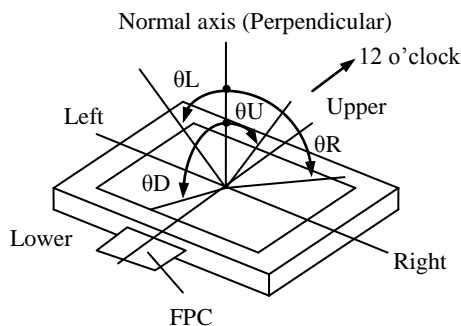

**5. ESTIMATED LUMINANCE LIFETIME**

The luminance lifetime is the time from initial luminance to half-luminance.

**This lifetime is the estimated value, and is not guarantee value.**

Condition		Estimated luminance lifetime (Life time expectancy) Note1, Note2, Note3	Unit
LED elementary substance	25°C (Ambient temperature of the product) Continuous operation, PWM duty ratio: 100%	100,000	h
	80°C (Temperature at T/P surface and rear shield surface) Continuous operation, PWM duty ratio: 100%	70,000	



Note1: Life time expectancy is mean time to half-luminance.

Note2: Estimated luminance lifetime is not the value for LCD module but the value for LED elementary substance.

Note3: By ambient temperature, the lifetime changes particularly. Especially, in case the product works under high temperature environment, the lifetime becomes short.

6. RELIABILITY TESTS

Test item	Condition	Judgment	Note1
High temperature and humidity (Operation)	① $60 \pm 2^{\circ}\text{C}$ , RH= 90%, 240hours ② Display data is black.	No display malfunctions	☆
High temperature (Operation)	① $80 \pm 3^{\circ}\text{C}$ , 240hours ② Display data is black.		
Heat cycle (Operation)	① $-30 \pm 3^{\circ}\text{C}$ ...1hour $80 \pm 3^{\circ}\text{C}$ ...1hour ② 50cycles, 4 hours/cycle ③ Display data is black.		
Thermal shock (Non operation)	① $-40 \pm 3^{\circ}\text{C}$ ...30minutes $80 \pm 3^{\circ}\text{C}$ ...30minutes ② 100cycles, 1hour/cycle ③ Temperature transition time is within 5 minutes.		
ESD (Operation)	① 150pF, 150Ω, $\pm 10\text{kV}$ ② 9 places on a panel surface Note2 ③ 10 times each places at 1 sec interval		
Dust (Operation)	① Sample dust: No. 15 (by JIS-Z8901) ② 15 seconds stir ③ 8 times repeat at 1 hour interval		
Vibration (Non operation)	① 5 to 100Hz, $19.6\text{m/s}^2$ ② 1 minute/cycle ③ X, Y, Z directions ④ 120 times each directions	No display malfunctions No physical damages	
Mechanical shock (Non operation)	① $539\text{m/s}^2$ , 11ms ② $\pm X$ , $\pm Y$ , $\pm Z$ directions ③ 5 times each directions		

Note1: Display and appearance are checked under environmental conditions equivalent to the inspection conditions of defect criteria.

Note2: See the following figure for discharge points.

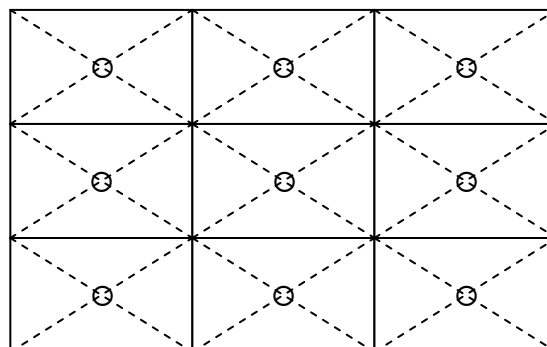

7. PRECAUTIONS

7.1 MEANING OF CAUTION SIGNS

The following caution signs have very important meaning. **Be sure to read "7.2 CAUTIONS" and "7.3 ATTENTIONS"!**

	This sign has the meaning that a customer will be injured or the product will sustain damage if the customer practices wrong operations.
---	--

	This sign has the meaning that a customer will be injured if the customer practices wrong operations.
---	---

7.2 CAUTIONS

	<p><b>* Be taken care when handling the T/P. There is a danger of injury, because the T/P has the glass edge and corner which are sharp.</b></p> <p><b>* Do not shock and press the LCD panel, T/P and the backlight! There is a danger of breaking, because they are made of glass. (Shock: Equal to or no greater than 539m/s<sup>2</sup> and equal to or no greater than 11ms, Pressure: Equal to or no greater than 19.6 N (φ16mm jig))</b></p>
---	---

7.3 ATTENTIONS



7.3.1 Handling of the product

- ① Use gloves or fingerstalls and do not touch glass edge of T/P when handling it, because it has sharp glass edge.

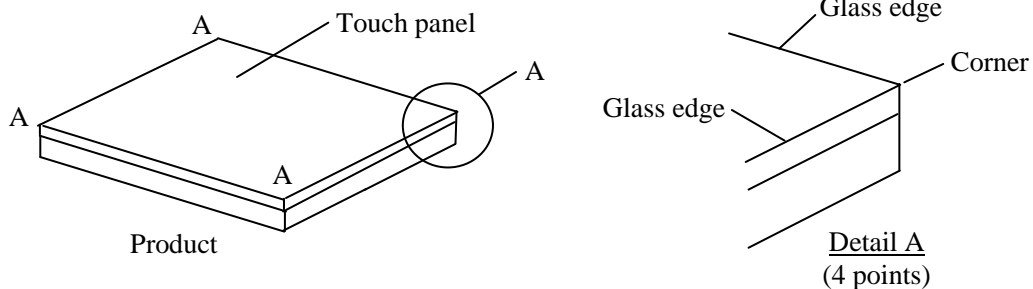

- ② Take hold of both ends without touching the circuit board when the product (LCD module) is picked up from inner packing box to avoid broken down or misadjustment, because of stress to mounting parts on the circuit board.
- ③ Do not hook nor pull the FPC in order to avoid any damage.
- ④ When the product is put on the table temporarily, display surface must be placed downward.
- ⑤ When handling the product, take the measures of electrostatic discharge with such as earth band, ionic shower and so on, because the product may be damaged by electrostatic.
- ⑥ The torque for product mounting screws must never exceed 0.230N·m. Higher torque might result in distortion of the bezel. And the length of product mounting screws must be ≤ 2.0 mm.
- ⑦ The product must be installed using mounting holes without undue stress such as bends or twist (See outline drawings). And do not add undue stress to any portion (such as bezel flat area). Bends or twist described above and undue stress to any portion may cause display mura.



- ⑧ Do not hit or rub the surface of T/P with hard materials, because it is easily scratched.
- ⑨ When cleaning the T/P surface, wipe it with a soft dry cloth.
- ⑩ Do not press or rub on the sensitive product surface.
- ⑪ Do not push or pull the interface connectors while the product is working.
- ⑫ When handling the product, use of an original protection sheet on the product surface is recommended for protection of product surface. Adhesive type protection sheet may change color or characteristics of the T/P surface. ☆
- ⑬ Usually liquid crystals don't leak through the breakage of glasses because of the surface tension of thin layer and the construction of LCD panel. But, if you contact with liquid crystal by any chance, please wash it away with soap and water.
- ⑭ When tuning on the power of the T/P, do not touch T/P surface with any conductive materials such as finger and so on. It may cause malfunction of the T/P. ☆

### 7.3.2 Environment

- ① Do not operate or store in high temperature, high humidity, dewdrop atmosphere or corrosive gases. Keep the product in packing box with antistatic pouch in room temperature to avoid dusts and sunlight, when storing the product.
- ② In order to prevent dew condensation occurred by temperature difference, the product packing box must be opened after enough time being left under the environment of an unpacking room. Evaluate the storage time sufficiently because dew condensation is affected by the environmental temperature and humidity. (Recommended leaving time: 6 hours or more with the original packing state after a customer receives the package)
- ③ Do not operate in high magnetic field. If not, circuit boards may be broken.
- ④ This product is not designed as radiation hardened.

### 7.3.3 Characteristics

**The following items are neither defects nor failures.**

- ① Characteristics of the LCD (such as response time, luminance, color uniformity and so on) may be changed depending on ambient temperature. If the product is stored under condition of low temperature for a long time, it may cause display mura. In this case, the product should be operated after enough time being left under condition of operating temperature.
- ② Display mura, flickering, vertical streams or tiny spots may be observed depending on display patterns.
- ③ Do not display the fixed pattern for a long time because it may cause image sticking. Use a screen saver, if the fixed pattern is displayed on the screen.
- ④ The display color may be changed depending on viewing angle because of the use of condenser sheet in the backlight.
- ⑤ Optical characteristics may be changed depending on input signal timings.
- ⑥ T/P film has polarizing characteristic. And the polarizer characteristics differ among products. Therefore, when seeing the displays through the other polarizing material (for example polarizing sunglasses), some displays can not be seen and some displays look different color darker because of polarizer characteristic mismatching between T/Pfilm and the other polarizing material.
- ⑦ If the product is subjected to direct sunlight for a long time, T/P transmission may be degraded.

7.3.4 Others

- ① All GND, VCC and VDD terminals should be used without any non-connected lines.
- ② Do not disassemble a product or adjust variable resistors.
- ③ Pack the product with the original shipping package, in order to avoid any damages during transportation, when returning the product to NLT for repairing and so on. ☆
- ④ The information of China RoHS directive six hazardous substances or elements in this product is as follows. ☆

China RoHS directive six hazardous substances or elements					
Lead (Pb)	Mercury (Hg)	Cadmium (Cd)	Hexavalent Chromium (Cr VI)	Polybrominated Biphenyls (PBB)	Polybrominated Biphenyl Ethers (PBDE)
×	○	○	○	○	○

Note1: ○: This indicates that the poisonous or harmful material in all the homogeneous materials for this part is equal or below the limitation level of SJ/T11363-2006 standard regulation.

×: This indicates that the poisonous or harmful material in all the homogeneous materials for this part is above the limitation level of SJ/T11363-2006 standard regulation.

8. OUTLINE DRAWINGS

8.1 FRONT VIEW

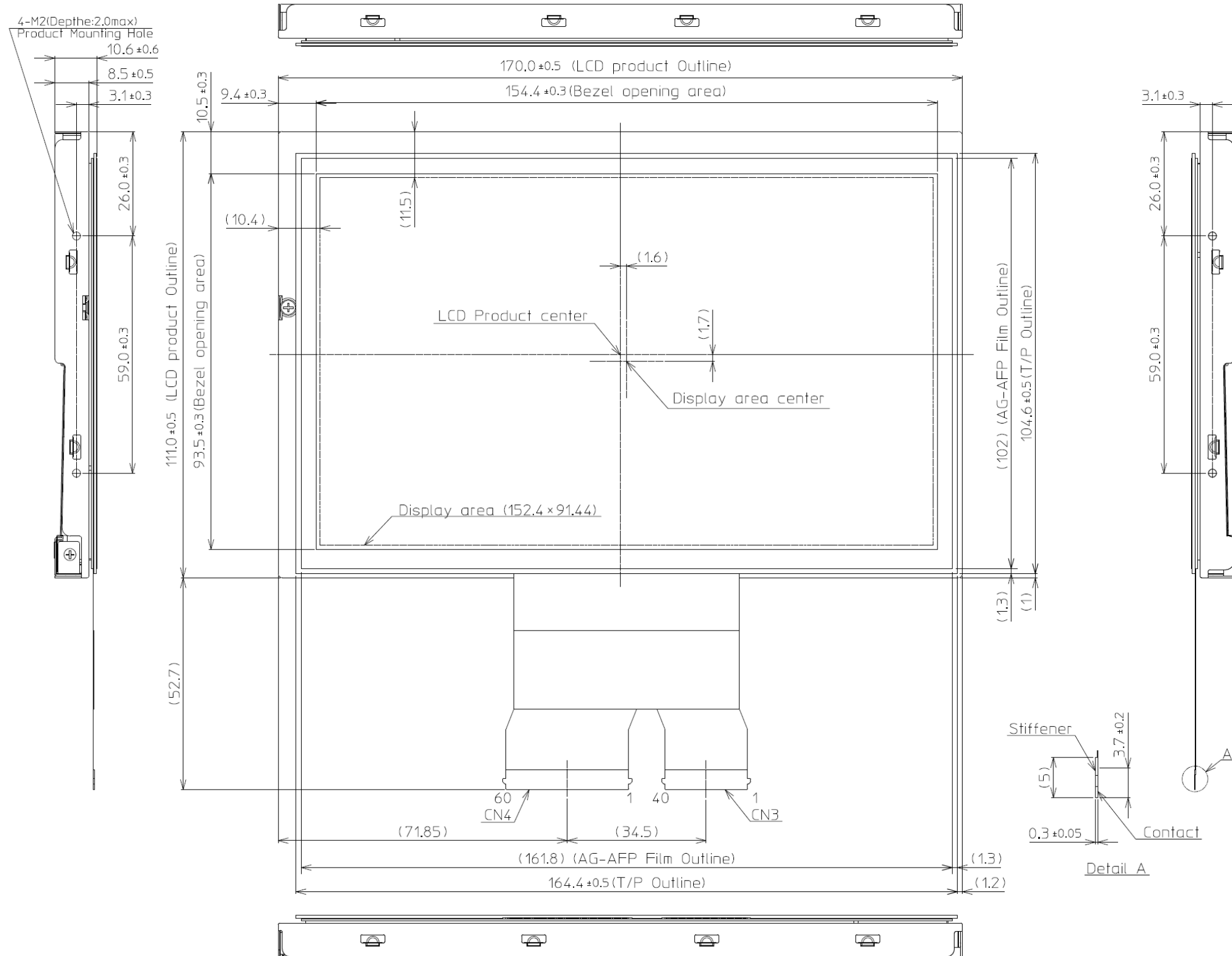

Unit: mm

Note1: The values in parentheses are for reference.

Note2: The torque for product mounting screws must never exceed 0.230N·m. And the length of product mounting screws must be ≤ 2.0 mm.

8.2 REAR VIEW

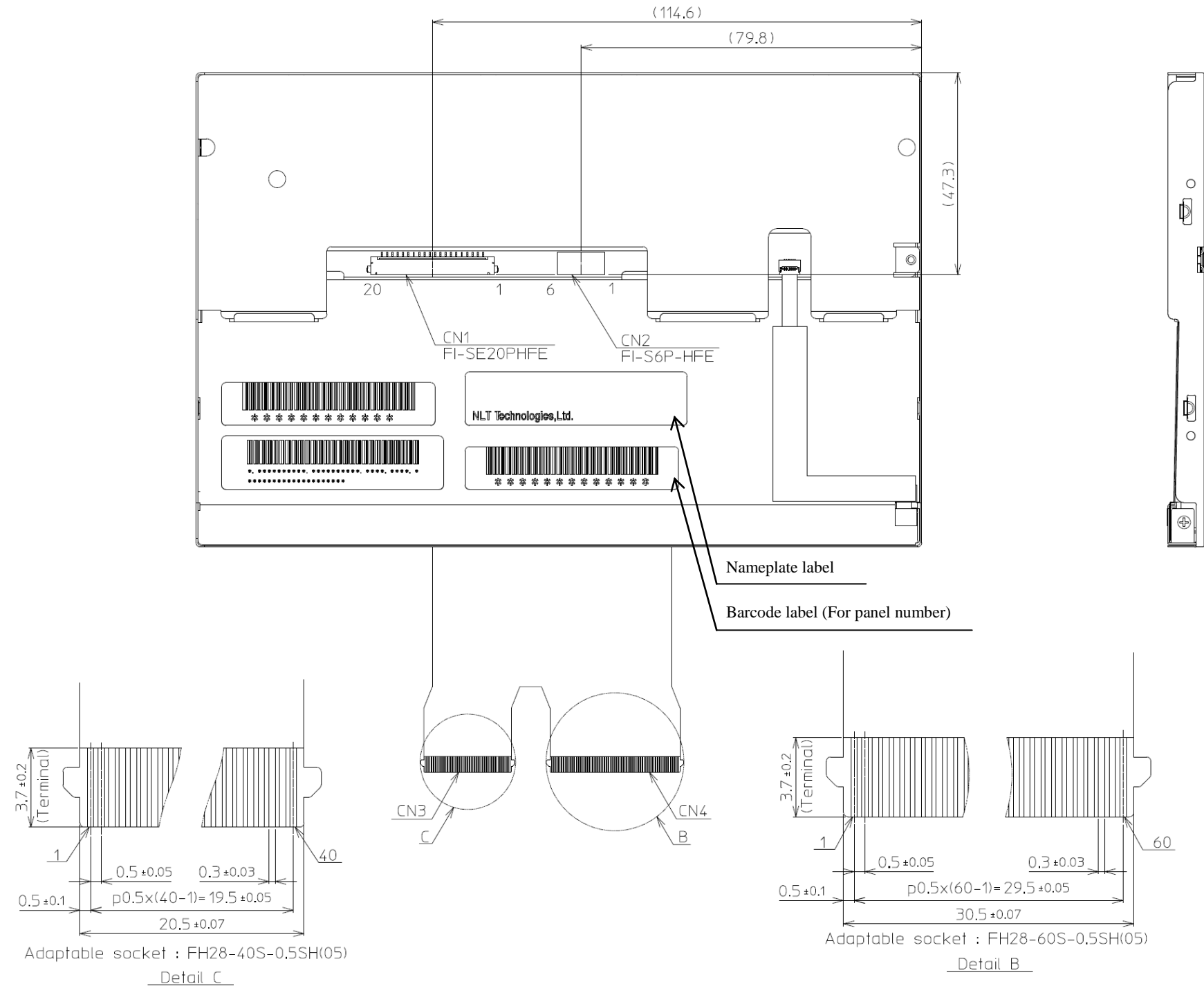

Note1: The values in parentheses are for reference.

INSTALL GUIDANCE

1. Bezel mounting

If a customer put a front bezel on the T/P, please take care the following items.

- Use a front bezel made from an insulative material such as plastic and so on.
- If a customer use a front bezel made from a conductive material, please always keep a distance more than 1mm between the front bezel and the T/P. Otherwise, the bezel will lower T/P sensitivity or cause unstable touch action.

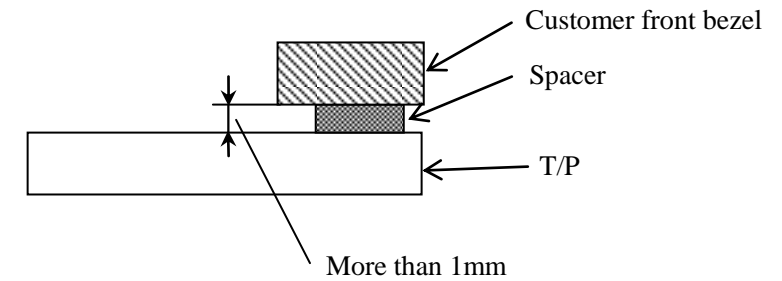

2. FPC handling

- Do not fold the FPC. If the FPC is folded, disconnection of a wiring pattern may be caused. In case of bending FPC, the minimum radius of curvature must be 1.0mm or more.
- Do not bend the FPC at the reinforced area (A).

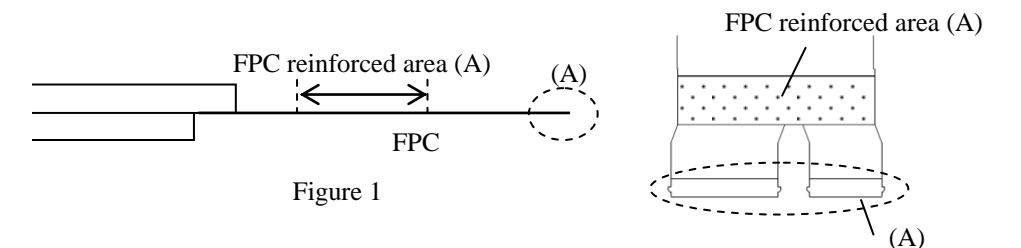

• Bending direction

To avoid any mechanical damage to the base part of the FPC, please always bend the FPC at the outer side of the LCD module in the direction of the arrow in Figure 2.

- Allowable number of bending  
30 times

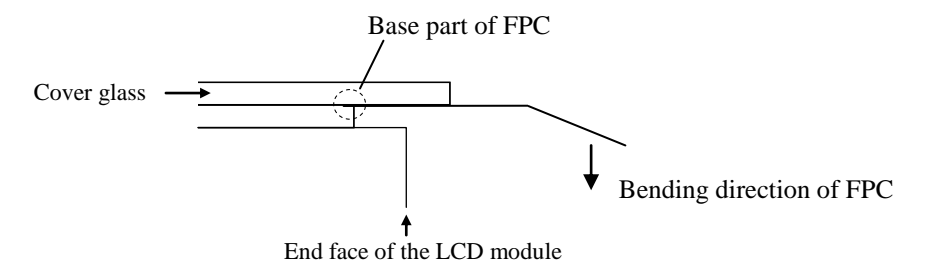

Figure 2

Unit: mm

